

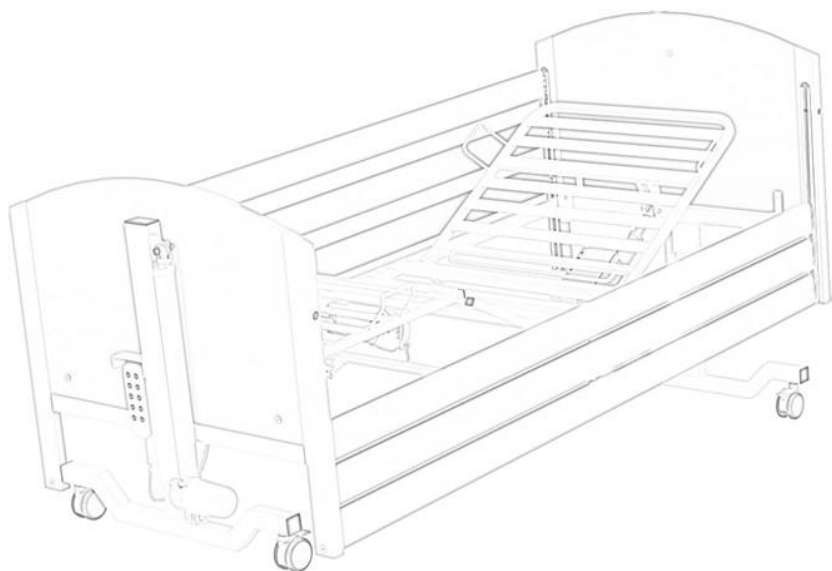

## INSTRUCTIONS FOR USE

---

# TAURUS JUNIOR



## WELCOME TO REHA-BED

Reha-Bed is a Polish family company specializing in the production of the highest-quality rehabilitation beds and a wide range of products that support the care, rehabilitation, as well as long-term and short-term care.

Thanks to the fact that we not only produce and design our equipment but also are very flexible and can adapt to the requirements of our clients. Thanks to over 15 years of experience in the industry, we can advise our clients with full responsibility and help them to choose the most optimal equipment.

We meet the needs of our clients, search innovative solutions and constantly strive to expand our offer.

Reha-Bed Sp. z o.o. places the greatest emphasis on the high quality of components and materials used in production. It takes advantage of extensive experience and knowledge of world-class suppliers of actuators, driving systems and fasteners. The dynamically developing technology of our company ensures the highest quality of steel and wooden elements for the produced assortment. Precise control of our products is a guarantee of the future satisfaction of our clients.



### R&D Department

Engineers, designers and constructors responsible for development, improvement and expansion of the range of products.



### Production Department

Our production is based on modern world-class equipment and experience of our employees.



### Employment

Over 50 qualified employees employed in the production department.



### Area

Warehouse and production halls, as well as office space with a total surface exceeding 4500m<sup>2</sup>.

# CONTENTS

---

<b>1. INTRODUCTION.....</b>	<b>4</b>
1.1. CONTACT .....	4
1.2. TO WHAT IT CONCERNS .....	4
1.3. FEATURES .....	5
1.4. USE .....	5
1.5. CONTRAINDICATIONS.....	6
<b>2. GENERAL WARNINGS .....</b>	<b>7</b>
2.1. GENERAL WARNINGS .....	7
<b>3. TRANSPORT AND STORAGE.....</b>	<b>11</b>
<b>4. SYMBOL DEFINITIONS .....</b>	<b>14</b>
<b>5. PARTS .....</b>	<b>16</b>
5.1. PARTS SPECIFICATION .....	16
<b>6. BED ASSEMBLY AND PREPARING FOR USE .....</b>	<b>17</b>
6.1. REMOVAL FORM THE TRANSPORT STAND	17
6.2. ASSEMBLING THE BED .....	18
6.3. FITTING ELECTRICAL SYSTEM.....	19
6.3.1. HOLDER ARRANGEMENTS ON	
POWER CABLE .....	20
6.4. FITTING THE SIDE RAILS .....	21
6.5. CHECKING THE BED.....	23
<b>7. TRAINING.....</b>	<b>24</b>
<b>8. FIRST USE.....</b>	<b>25</b>
8.1. GENERAL SAFETY.....	25
8.2. PREPARING FOR START .....	26
8.3. BRAKE SYSTEM .....	27
8.4. SIDE RAILS AND MATTRESSES .....	27
8.4.1. MATTRESS THICKNESS .....	27
8.4.2. OPERATING THE SIDE RAILS .....	27
8.5. ELECTRICAL OPERATION .....	28
8.5.1. HANDSET LOCATION .....	29
8.5.2. 9-BUTTON HANDSET OPERATION	30
8.5.3. HANDSET LOCKOUT .....	31
8.6. LEG SECTION.....	31
<b>9. ASSEMBLY ONTO THE TRANSPORT</b>	
<b>STAND .....</b>	<b>33</b>
<b>10. POWER FAILURES .....</b>	<b>35</b>
10.1. EMERGENCY LOWERING BACKREST AND	
LEG SECTIONS.....	35
<b>11. DECONTAMINATION .....</b>	<b>37</b>
<b>12. MAINTENANCE.....</b>	<b>39</b>
12.1. GENERAL MAINTENANCE .....	39
12.2. SERVICE LIFE .....	41
12.3. FAULTY FINDING.....	42
<b>13. DISPOSAL OF PARTS .....</b>	<b>43</b>
<b>14. ELECTROMAGNETIC COMPATIBILITY</b>	
<b>(EMC) .....</b>	<b>44</b>
<b>15. SPECIFICATION .....</b>	<b>45</b>
15.1. BED DATA .....	45
15.2. MAXIMUM LOAD.....	45
15.3. TECHNICAL DATA OF SIDE RAILS .....	45
15.4. ELECTRICAL DATA .....	47
<b>16. ACCESSORIES .....</b>	<b>48</b>
16.1. MATTRESSES AND SIDE RAILS .....	48
16.2. LIFTING POLE .....	49
16.3. LOCKBOX.....	50
<b>17. WARRANTY .....</b>	<b>52</b>
17.1. WARRANTY TERMS AND CONDITIONS..	52
<b>18. REPAIRS AND SERVICING.....</b>	<b>54</b>
<b>19. REMARKS AND NOTES.....</b>	<b>55</b>

## 1. INTRODUCTION

---

Thank you for your trust and purchase of our product. The user should carefully read this instruction manual before using the bed. Please ensure that you understand all instructions. In the case of any doubts concerning the installation, use or maintenance of the bed, please contact the seller or the manufacturer.

### 1.1. CONTACT

In order to get help with the installation, use or service of the product, as well as to report an unexpected operation or to obtain any information regarding service, warranty, sales or customer service concerning this product, please contact your seller or the manufacturer at the following address:

Reha-Bed Sp. z o.o.  
Spacerowa 1 Street  
41-253 Czeladź  
Poland

In service matters (including spare parts):

e-mail address: [serwis@rehabed.com.pl](mailto:serwis@rehabed.com.pl)

phone: +48 519 842 766

phone: +48 608 727 090

Other issues:

e-mail address: [biuro@rehabed.com.pl](mailto:biuro@rehabed.com.pl)

phone: +48 608 727 090

Each serious incident connected with the device should be reported to Drive DeVilbiss Healthcare Ltd., Reha-Bed Sp. z o.o. and the competent authority of the Member State, where the device is used. Please provide the product serial number (SN) in all correspondence. You can find it on the identification labels, which are located on the inside of the backrest section frame and the leg section frame, as well as on the bottom of each bed ends.

In order to receive support outside of Poland, please contact the local distribution company, which sold you the device.

### 1.2. TO WHAT IT CONCERNS

This manual covers the scope of the type Taurus Junior, consisting of 4-section mattress platform with metal slats and electrically operated backrest and knee break.

All products are CE marked – in accordance with the Regulation (EU) 2017/745 on medical devices (MDR).

### 1.3. FEATURES

- 4 separate sections (adjustable head and foot sections)
- Electrically operated backrest and thigh section
- Mechanically adjustable lower leg section
- Auto contour – simultaneous adjustment of backrest and knee-break sections
- Variable electrically operated bed's height and foot down tilt (reverse Trendelenburg)
- Lockable handset (remote control)
- Available LOW version with a reduced minimum and maximum height of the mattress platform compared to the standard bed
- Possibility of disassembling into four separate parts stored and/or transported on the transport stand
- Wooden full length 3 bar side rails
- Transport stand to aid storage and bed transportation
- Electrical system IPX4 rated – Splash resistant

### 1.4. USE

Taurus JUNIOR has been designed to provide users with optimum independence and freedom of movement whilst aiding the manual handling requirements of the carer. The bed is operated by 9 button handset. Taurus Junior beds are intended for use within domestic and long term care environment (e.g. care homes, rehabilitations homes). The bed largely relieves the care person owing to fully electrically contoured mattress platform allowing for matching position to the needs of the patient.

Taurus Junior bed is designed for users with a minimum height from 125 to 166 cm and a maximum weight up to 178 kg. The lower (or upper) age limit is not defined. The usability of the bed depends on the physical size of the patient in relation to the various proportions and spaces around the bed's frame.

The bed is intended for one person only!

The bed is designed to support the patient's weight (as described above) while sleeping or resting. It assists in the care and/or ensures comfort for the patient or caregiver – when the bed is used in long-term care facilities.



- For patients who fall outside of the stated patient parameters the Taurus Junior bed is unlikely to be suitable for use due to its proportions and could create an entrapment hazard. Ensure a risk assessment is performed on a patient by patient basis to ensure of product suitability.



- **If there are any doubts to use the product should be consulted with a health care professional (e.g. physiotherapist, doctor). Make sure the product is suitable for your condition or dysfunction.**

### 1.5. CONTRAINDICATIONS

The contraindications for using the Taurus Junior bed include:

- Cervical or skeletal traction,
- Unstable fractures of the spine – if the bed's functions remain unlocked,
- General fractures of the skeleton – if the bed's selected functions remain unlocked,
- Level of mental development that makes it impossible to safely operate the bed's functions – if the bed functions remain unlocked,
- Confusion, agitation or unstable emotional state of the patient – if side rails are installed and/or they are in the highest position,
- Exceeding the maximum patient's weight,
- Inadequate height of the patient (below 125 cm or above 166 cm).

Consider the presence of other contraindications that are specific for the patient of the care environment.

## 2. GENERAL WARNINGS

---



**Warnings** in this instruction manual are potential hazards that if neglected, can lead to injury or death.



**Cautions** in this instruction manual are potential hazards that if neglected, can lead to damage of the device.

### 2.1. GENERAL WARNINGS



- Before you use or installation please read the instruction manual carefully.
- The user is obliged to observe these instructions.
- The bed is to be installed and put into service in accordance with the information provided in these instructions for use.
- The bed should be used according to its intended purpose.
- The bed is not suitable for users with a height less than 125 cm – in case of doubt, please contact the local distributor, importer or manufacturer.
- The bed is not suitable for users weighting more than 178 kg – in case of any doubt, please contact the local distributor, importer or manufacturer.
- Misused electrical equipment may be hazardous.
- Accessories that have not been designed for use with the bed should not be used.
- The use of additional mechanical or electrical devices not intended for use with the bed is unacceptable.
- Only original spare parts supplied by the manufacturer are allowed.
- The bed cannot be used in case any screws are missing.
- During transport, hold only the constant, massive parts of the bed ends!
- During assembly / disassembly and regular operation, particular attention should be paid to the risk of hand injury.
- Start and use of the defective device that could pose a risk to patients or others is forbidden.
- Actuators should not be used in the presence of flammable gases.



- The bed should be used and kept away from heat sources and open flames (e. g. cigarettes, electric fire, heaters, etc.) – risk of explosion / fire.
- It is forbidden to open covers/lid of actuators, control box and power supply! Disassembly and seal break will void the warranty and create risk of electric shock!
- Particular attention should be paid to current wiring not being among movable parts of backrest / leg section and high / low system of the bed, which may cause malfunction.
- All lines must be suspended on dedicated brackets, so they are not frayed and do not touch the floor.
- Ensure the mains cable is plugged into an appropriate power source at all times.
- The mains plug is the disconnect device for the means of isolating the bed from the mains supply, the plug must be accessible at all times.
- Pulling the plug out of the socket is permissible only for holding the body of the plug / adapter, not the cord.
- Inappropriate handling / positioning of the mains cable could cause kinking or shearing of the cable which may lead to exposed live wires - Risk of electrocution.
- If you cannot plug the main power cable directly into a wall socket, only the CE marked extension cables may be used.
- If the product is connected to the power supply with an extension cable, never overload the product by connecting devices that exceed the maximum rating of the extension cable – risk of fire.
- Make sure that there are not many sockets under the frame – liquids that may seep into such a socket during normal use of the bed may pose electrical/fire hazard.
- The place of use of the bed there should be no obstacles to the proper operation or installation.
- Setting up and using the bed should be on flat, horizontal surfaces so that all the castors touch the ground.
- Before each use, check the bed and lock all four wheels.
- Wheels should be locked / unlocked by foot, not by hand.
- The bed should be in the lowest position if the patient is left unattended, in order to minimize the risk of injury caused by a fall.
- A handset must be locked when there are doubts concerning the patient's ability to safely control the functions of the bed. This includes the ability to lock out the handset and the option



to use a handset lockbox. Please refer to chapter 8.5.1. detailing the use of the handset lockbox.

- In the absence of supervision of the patient (if such circumstances occur), the bed should be set to the highest position of railings on both sides of the bed. Unlocking and lowering them can be done only by the person responsible (care person or nurse).
- The patient should not be left in the reverse Trendelenburg position!
- The bed is not intended for patient's transportation. The manufacturer allows moving the bed with patient within the room to clean or gain access to the patient. The transportation should take place in the lowest position of the mattress platform while maintaining the patient in the horizontal lying position.
- Safe working load of the bed and lifting pole should not be exceeded!
- In the case of the event of lifting pole's deformation, it should be immediately replaced with a new one.
- Side rails must be installed on both sides of the bed (on the side of the wall as well).
- With standard length side rails, the height of the mattress is 115 mm to 140mm.
- Side rails may only be used with proper size mattresses intended for the bed – otherwise there is a risk of the user entrapment.
- Leaning against or resting on rails may cause accidents!
- Leaning out of the bed is a threat of injury!
- In case of damage to the rails (bending, breaking, cracking etc.), they should be immediately replaced with new ones due to the risk of an accident.
- Placing limbs between the moving elements of the bed may cause injury and accidents.
- Maximum operating time of actuators is **2 minutes for 18 minutes break**. Failure to comply with the afore-mentioned will result in permanent damage to the actuator.
- During the adjustment and maintenance attention should be paid to ensure that no part of the body is found in the potentially hazardous section (movable: backrest section, leg section, high / low system, side rails) - risk of injury to the limbs!
- Particular attention should be paid to small children, the patient's limb or other items around the bed that could entrap



- in a space between mattress platform and the chassis and be damaged or injured.
- Do not sit on the raised sections of the back, thigh and lower leg.
- Bear in mind that self-repair poses a risk of accidents or damage to the bed!
- Maintenance, repair and disinfection may be conducted only by specially trained persons.
- It is forbidden to modify the bed's frame without the consent of the manufacturer – this poses a risk of danger.
- Precautions are to be taken when routing cables from external equipment around the bed to ensure that they do not become squeezed, trapped or damaged - risk of electric shock and/or fire.
- All electrical components that are a part of the bed and/or related accessories, which are damaged, loose or worn (such as actuators, cables, plugs, or the handset), must be immediately withdrawn from use and replaced – damaged electrical components may lead to malfunction or pose a risk of electric shock/ fire.
- If the bed will be used with a hoist, make sure that there is enough space under the bed to lower the bed to the lowest possible position of the mattress platform – risk of crushing of the bed's frame.
- The RF emissions from the electrical system are very low and are not likely to cause any interference to nearby electronic equipment, however interference to sensitive equipment is possible (see section 14 for further detail).
- **ALL THE ABOVE WARNINGS AND CAUTIONS SHOULD BE STRICTLY ADHERED TO.**

### 3. TRANSPORT AND STORAGE

---

The following conditions should be followed when transporting and storing the bed:

- Bed always to be stored on transport stand.
- Bed always to be stored on a flat and level floor.
- Bed ends set to minimum height.
- Side rail components (not including wooden side rails) to be kept in the aluminium channel on the bed ends (or stored safely together).
- Brakes applied.
- All profiling sections secured with hook and loop tape (or similar).
- All functions locked out.
- Make sure that all fasteners (such as screws, washers, plugs, etc.) are carefully tightened and secured for transport.
- Covered to protect from fluid ingress, dirt, dust etc.
- Beds must not be stored one on top of another.
- Beds not to be stored on their side.

Environmental conditions:

	<b>Operational Limits*</b>	<b>Transportation/storage limits</b>
Ambient temperature:	from +10°C to +40°C	from -20°C to +50°C
Humidity:	30% - 75%	30% - 75%
Atmospheric pressure:	from 800 to 1060 hPa	from 800 to 1060 hPa
Altitude:	≤ 2000 m	≤ 2000 m

\* Always ensure the bed is brought up / down to room temperature before plugging in and operating. It is recommended to leave the bed for at least 2 hours in order to ensure that it reaches room temperature.

---

Shelf life:

The expected maximum storage period of the bed before first use is equal to the bed's service life, provided that the above environmental conditions are met.



- The bed is not intended for patient transport, it is not to be moved out of the room it is located in with a patient occupying the bed - Risk of patient / carer injury. If the bed is to be moved within the room with an occupant in the bed a risk assessment in line with local health and safety policy is to be undertaken in order to ensure that neither staff or patients are put at risk when moving the bed; this is dependent on the situation and load on the bed.
- If transporting the bed whilst on its transport stand ensure a risk assessment in line with local health and safety policy is undertaken to ensure that staff are not put at risk when moving



Warning

the bed, especially in regards to moving up / down inclines and uneven surfaces.

- The bed should not be transported on the transport stand in the absence of screws or unsecured sections – the risk of bed's collapse.
- In order to prevent the risk of cross contamination, when removing the bed from its place of use by the end user, make sure that all actions (connected with the bed) are carried out with the use of disposable gloves. Next to, properly dispose the glove, unless it can be verified that the bed and all accessories have been properly disinfected and cleaned.
- If the bed is removed from its place of use by the end user, before handing the bed over for storage, make sure that the bed has been cleaned and disinfected – in acceptance with your local infection control rules and/or rules that are specified in this instruction manual (see section 11).



Caution

- Avoid excessively low or high temperatures during use, storage, and transport of the bed (see section 15.4). Exceeding the recommended temperature range poses a risk of damage to the electrical system (e.g. when the bed is placed near heat sources such as radiators, space heaters, fireplaces or in cold environments such as unheated storage rooms).
- If the bed has been transported/stored at a temperature close to the minimum/maximum values determined above, it should be left for a minimum of 2 hours in order to reach room temperature before its connection to the power supply – operation outside the recommended temperatures poses a risk of damage to the electrical system.
- Avoid exposing the bed to direct sunlight – direct sunlight may damage the electrical system and/or cause bed's colour fading over time (including the fading of the bed's labels).
- Avoid placing the bed in a humid environment – a long-term exposure to moisture (e.g. from devices such as air humidifiers, nebulisers, steam kettles or inadequate room ventilation) may damage the electrical system and/or have a detrimental effect on parts of the bed's frame.
- Wooden and wood-based elements are not waterproof. Exposing the product to moisture, flooding, or prolonged dampness constitutes use contrary to the operating



instructions and may lead to permanent damage to the product. Cleaning and disinfection must be carried out in accordance with the information contained in this operating manual.

- During use, natural changes in the wood may occur, such as cracking, colour changes and fading of the impregnation, knots falling out, or resin exudation. These result from the properties of the material and the influence of external factors, including UV radiation and environmental conditions.
- Differences in shade within a single wood colour result from the natural non-uniformity of the wood structure and do not constitute a product defect or grounds for a complaint.
- Avoid the accumulation of dust, lint, or other contaminants, as they may interfere with the proper functioning of the bed and electrical system. To ensure safe and reliable use, the bed should be cleaned regularly.
- Do not use side rails to transport the bed – the risk of damaging side rails/bed's frame.
- Do not transport the bed over threshold – this may damage the frame.
- When using the bed's functions, make sure that no furniture or other things (such as a bedside table) are not an obstacle.
- Make sure that the bed is positioned in an appropriate distance from walls/other furniture in order to prevent the damage to the equipment when operating the bed (especially when working with a tilted mattress platform).
- Cable tiles, etc. used for storage should be removed after assembling the bed, before use – the frame may be damaged in the event of their leaving.
- Take special precautions concerning EMC. The bed should be installed and put into operation in a manner described in section 14.

## 4. SYMBOL DEFINITIONS

---

The following symbols are found on this bed:



**Warning**  
Beware of potential hazard



**Refer to instructions for use – Recommended**  
Failure to read the instructions for use could introduce a hazard



**Refer to instructions for use – Mandatory**  
Failure to read the instructions for use could introduce a hazard



**Maximum patient weight**



**Safe working load**



**W.E.E Label - Found on individual parts of electrical system**  
(Waste Electrical and Electronic Equipment)



**Type BF Applied Part**  
Applied Part: The parts of the device that come into physical contact with the user/occupant in order for it to carry out its intended function  
Type BF: Applied parts which are electrically isolated from earth and other parts of the medical equipment - Complying with specific requirements for protection against electric shock to IEC 60601-1.



**Class II electrical device**  
The user/occupant is protected by at least two layers of insulation between the current carrying parts (e.g. mains cable) - if damage is noticed to the control unit or mains cable assembly turn off at the mains supply and contact your provider immediately.



**Marking of the medical device**



**Mattress suitability**



**Minimum and maximum patient height**



**Proper patient positioning**



### Handset



**Warning – knee break intended purpose**  
Knee break to be used for lifting patient legs only

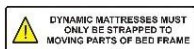

**Warning – dynamic mattress**  
Dynamic mattresses must only be strapped to moving parts or bed's frame

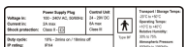

**Electrical specification**  
Including storage and use conditions

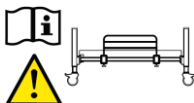

**Warning – removable side rail**  
Incompatible and improperly installed side rails may pose a risk of injury or death - see the instruction manual



87 kg-90 kg

**Total product weight on the transport stand**  
Heavy weight of the product - be careful when transporting on the transport stand and assembly



**Warning regarding the transport on the transport stand**  
The risk of loss of stability/overturning of the product - be careful when transporting the product on the transport stand



**Certification mark**  
Product meets the requirements of the Regulation (EU) 2017/745 on medical devices (MDR)



### Manufacturer data



**DOM**  
Date of manufacturing



**SN**  
Serial number



**Reference number**  
Product code

## 5. PARTS

### 5.1. PARTS SPECIFICATION

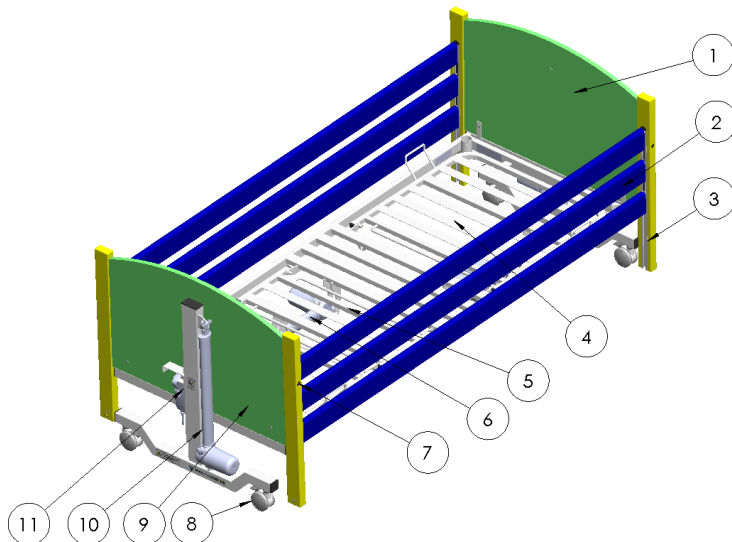

(The figure shows the Taurus Junior LOW bed with wooden side rails)

1. Head end (actuator with blue marker)
2. Side rail
3. Side rail channel
4. Backrest mattress platform
5. Leg section frame
6. Leg rest actuator
7. Side rail release button
8. Castor
9. Foot end (actuator with white marker)
10. High / Low actuator
11. Handset
12. Backrest actuator and control box – (not visible)



- During assembly / disassembly and regular operation, particular attention should be paid to the risk of hand injury.
- The bed cannot be used in case a screw is missing.

## 6. BED ASSEMBLY AND PREPARING FOR USE

### 6.1. REMOVAL FORM THE TRANSPORT STAND



- Before attempting to assemble the bed, ensure these instruction manual has been read and fully understood.
- Ensure a risk assessment in line with local health and safety policy is undertaken to ensure that staff are not put at risk when performing assembly activities.
- Be careful while taking bed parts off the transport stand. The parts are heavy.
- The manufacturer recommends that the bed should be assembled by two persons.

- For assembly, clear the intended area, paying particular attention to the fact that any movement of the bed will not be obstructed.
- Apply the brakes to all 4 castors.
- Loosen handle wheel binding leg section then lower it and gently put aside on the floor.
- Loosen grub screws with Allen key (supplied) binding backrest section with the stand. Then lower it and gently put aside on the floor.
- Loosen hand wheels on transport stand. Rest it carefully against the wall or on the floor. **Caution, once the transport stand is removed, neither bed top stays up unsupported.**
- Remove transport stand off the other bed end and keep it (in the case of possible disassembly of the bed).
- Now the bed is disassembled.

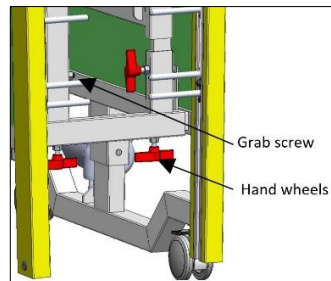
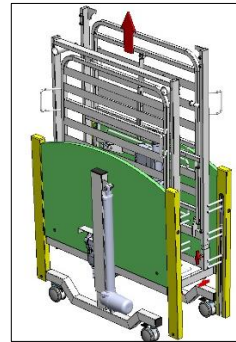

## 6.2. ASSEMBLING THE BED

- Fit the head bed end (blue marker on the actuator cable) sliding the spigots into the backrest mattress platform end and determine the position of the set screws. **Do not fully tighten the screws!**
- Fit the foot bed end (white marker on the actuator cable) sliding the spigots into the leg mattress platform end and determine the position of the set screws. **Do not fully tighten the screws!**

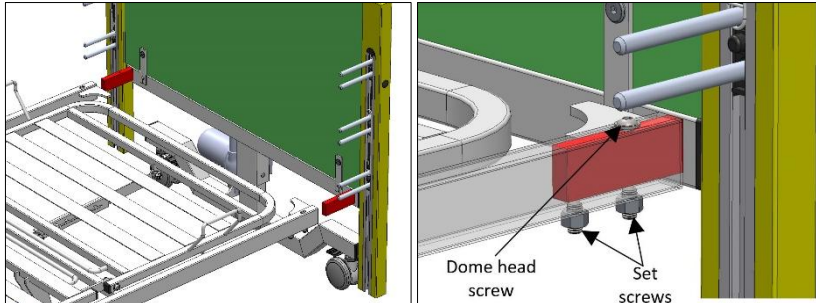

- Release brakes on two wheels in a selected bed end.
- Fit both bed ends and determine the position of hex screws at the bottom. Tighten all 4 set screws at the bottom of the mattress platform.

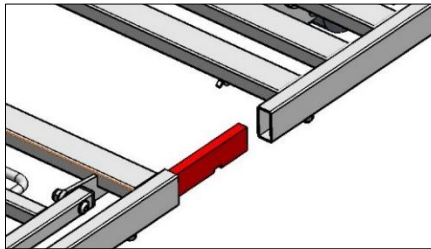

- Once the both halves are together tight all sets screws (12 piece under mattress platform) and 4 dome screws (4 pieces on each corner of top mattress platform). **Set screws must be tightened before dome heads screws.**
- Remove all packaging, e.g. cable ties securing the platform sections.



The bed cannot be used if any of the set screws or dome head screws is missing – the risk of the bed's collapsing.



Make sure that all packaging parts that secure movable sections (such as cable ties, foils, tapes, etc.) have been removed before the bed is put into service – otherwise, there is a risk of damaging the bed's frame.

### 6.3. FITTING ELECTRICAL SYSTEM

The bed is designed to be connected to a constant power supply.

- Before starting assembly works, check the condition of the power cable, handset cable, actuator cables and batteries located in the control box (if included in the set) and make sure that they are not damaged.
- Next to, remove the retaining cable cover to the control box (screwdriver required) and plug the actuator and handset cables into the control box as shown in the control box label and the picture below.

**Note:** The plugs only fit into the ports in one orientation. Ensure the cables are plugged fully into the control box.

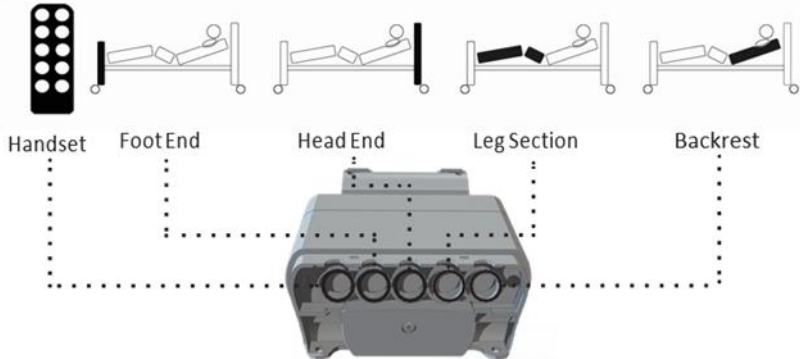

- Once all the cables are connected they are to be secured in place by attaching the supplied retaining clip. Clip the retaining clip to the control box.

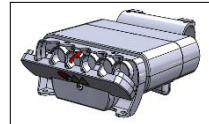

Actuator and handset cables are not shown

- The mains cable exiting the control unit is to be connected to the power supply plug. Take the 2 plugs and push them together, ensuring the connection has been fully made.



Drawing source: DewertOkin GmbH

- Make sure that actuator cables have sufficient length and they are not over-tightened – the full range of movement for actuators should be possible.
- Caution!** Connecting the bed end actuators to the correct port is crucial for the tilt function to work as intended.
- Clip the mains cable into the clip on the head end section of the bed.

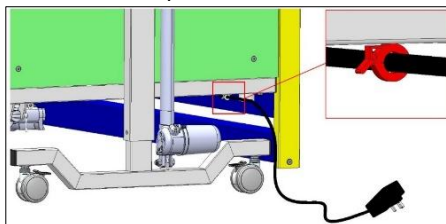



- Make sure that none of the actuator and/or handset cables are placed between moving parts of the bed and are not under excessive tension, and check that cables are not tight (especially the main power cable when lifting the bed up and down and/or backrest section control cable) to avoid possible damages. Damaged cables pose a risk of electric shock and/or fire.
- Make sure that both actuators (high/low) are plugged into the correct ports. If the reverse-Trendelenburg function does not work as expected, the high/low actuators can be connected in a wrong way.



- Damage to actuators or the control box will void the warranty.
- Breaking or damaging seals of actuators or the control box will void the warranty.

### 6.3.1. HOLDER ARRANGEMENTS ON POWER CABLE

Taurus Junior bed is equipped with 6 additional cable holders that allow the power cable suspension under the surface of the mattress. The picture below shows the arrangement.

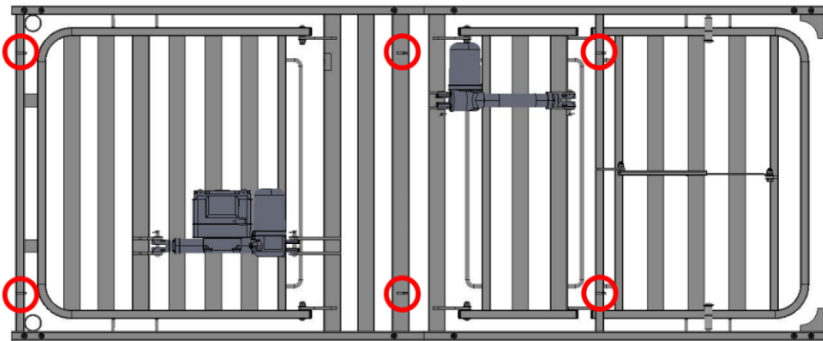

- All cables must be suspended from the platform frame on dedicated brackets, to avoid rubbing and cannot touch the floor.
- Incorrect placement/deployment of the power cable may cause the damage or cut of the cable – this situation may expose live conductors (risk of electric shock).

- Consider the adequate placement of actuator and/or handset cables in order to minimize the risk of accidental suffocation as a result of the entanglement of the user and/or other people.

#### 6.4. FITTING THE SIDE RAILS

Before installation, make sure that the length of side rails is suitable for the length of the mattress's platform.

- Lower / raise the bed to mid height (see section 8.5). Depress each end's side rail release button (see section 8.4.2) and lower the finger assemblies to the bottom of the channel.
- On the foot end, remove the retaining screw at the bottom of the Side rail channel on one side. **Do not remove head end retaining screws.**
- Remove the finger assembly from the channel.

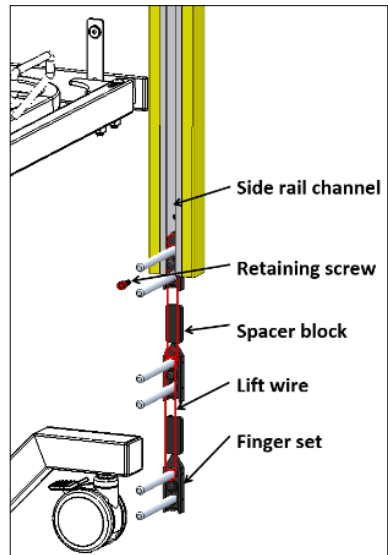
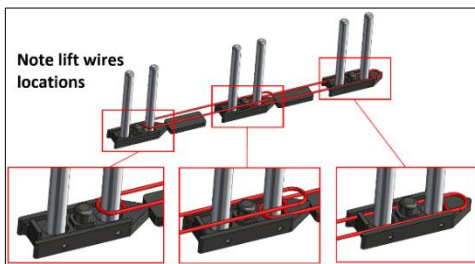

- Take the lift wire (4 lift wires are attached to the bag with IFU) and put it onto the middle and bottom finger sets as it shown in the picture on the right. Bottom lift wire must be located outside side rail channel.

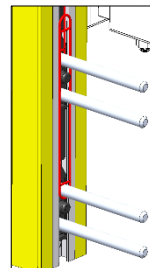

- Now take three side rails (rounded face pointing upward) and slide the end of them into both sets of fingers that are still located in the channel at the head end of the bed. Carefully rest the unattached ends on the floor taking care to ensure that the other ends are sufficiently far into the fingers so that they will not fall out.

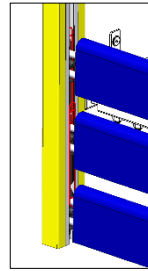

- Take the previously removed finger assembly, place the upper lift wire over the top finger set and insert into the other end of the top side rail. Slide the finger assembly inside the channel (as shown in illustration to the right). It is recommended that a second person holds the rail at this point.

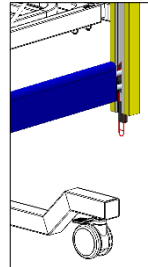

- Whilst holding the top side rail, slide the plastic spacer block into the channel and place the upper finger of the middle finger set through the hole in the upper lift wire and over the top in bottom lift wire (as shown in illustration to the right) and into the other end of the middle side rail. Bottom lift wire must be located outside side rail channel.

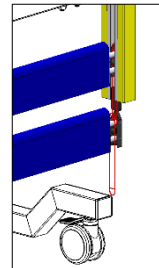
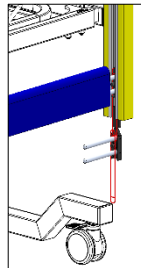

- Whilst holding the top and mid side rails slide the plastic spacer block into the channel and place the upper finger of the bottom finger set through the hole in the lift wire (as shown in illustration to the right) and into the other end of the lower side rail and lift the assembly until a click is heard.

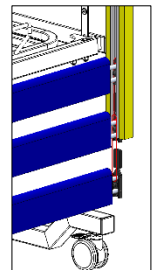
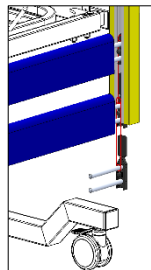

- Re-fit the previously removed retaining screw (This ensures that the side rail finger assembly cannot fall out of the channel when in the lowered position).
- Repeat the assembly process for the side rails on the other side of the bed.
- Check that the side rails function properly and smoothly. Check that the side rails easily lock into the highest position to make sure that they are mounted in a right way.



If there is any doubt about the assembly of the side rails contact the provider of the equipment, incorrectly fitted side rails can lead to death.

## 6.5. CHECKING THE BED

The bed is now fully assembled. Before the bed is put into use ensure the bed is correctly assembled:

- Are the grub and dome screws on all 4 corners of the bed fully tightened fully?
- Are the 2 grub screws on each side of the bed connecting the two halves fully tightened?
- Are the retaining screws for the side rails mechanisms inside the aluminium channel fully tightened?
- Has all packaging been removed, e.g. cable ties securing the platform sections?
- Are the cables free of all moving parts and is there sufficient slack in the cables to allow for movement?
- Is the bed clear of obstructions?
- Do the side rails raise/lower smoothly and lock automatically in the raised position?
- Has a risk assessment been performed on the suitability of the bed (and any ancillary equipment) for the user?
- Has the control box cable retaining clip been attached?
- Are plugs of actuators and power cable in the power box secured with the provided cover cap?
- Has the mains cable been attached to the securing clip on the head end of the bed?
- Has the bed (if necessary) been cleaned and disinfected before use?

In order to find details about the side rails and the mattress see section 8.4.



The bed cannot be used in case any screws are missing.



Make sure that all retaining straps have been removed from any bed parts. If not, the bed can be damaged.

## 7. TRAINING

---

Professional personnel should be appropriately familiarized with the functionality of the bed, its limitations and the target user group before use. The user's ability to operate the handset in an independent manner should be determined in acceptance with the risk assessment. The user should be familiarized with the handset and the functionality of the bed by a trained person as soon as possible – preferably before the use of this product. It is the responsibility of the end user to ensure they have received sufficient training to use the bed and any associated accessories safely and correctly.

It is the responsibility of the trained person to ensure that users are able to use this bed and any additional accessories in a safe and proper way. If the above-mentioned instructions are not sufficient and additional training is required, please contact your local provider or producer (see section 1.1), who is authorized to discuss training options.

## 8. FIRST USE

---

Prior to using the bed for the first time the following risk assessment must be performed based on the status of the patient and their body. This assessment should include, but is not limited to:

- The possibility of patient entrapment
- Fall out of bed
- The possibility of interference from children (and adults)
- Patients with learning disabilities
- Unauthorized persons
- Physical and mental condition of the patient
- Housing conditions
- Use of side rails and other accessories



- After assembling the bed, there should be no unused parts. However, the presence of spare parts (pins, holder, screws, etc.) should be taken into account to minimize the risk of ingestion by the patient, who use the bed and/or other persons – risk of choking.
- Functions of the bed should be blocked if there is any doubt regarding the patient's ability to safely operate the bed.
- Prior to each operating the bed ensure the brakes on all the castors have been applied.
- It is forbidden to start and use the product with defects that may pose a risk to users or other persons.
- If children, adults with reduced cognitive/learning abilities or (even) pets pose a potential risk of intentional or unintentional manipulating the bed, consider its suitability for use during the initial risk assessment of the patient/product.
- The bed in LOW version does not meet the height range and underbed clearance requirements for the IEC 60601-2-52 standard. If the potential risk is implemented by the requirements of the patient of caregiver, the use of a bed with standard height should be considered.

### 8.1. GENERAL SAFETY

- When the bed is operated, make sure that objects such as a bedside table or other furniture are not an obstacle.
- Before exploiting the bed, make sure that the patient has been positioned correctly.
- When the patient is left unattended, make sure that the bed is set at the minimum height.

- Keep distance of min 15 cm from the walls.
- Make sure all cables are not under excessive tension.
- If the bed is being used in conjunction with a hoist ensure the under bed clearances are checked before lowering the bed to minimum height - Risk of frames clashing.
- Make sure that every used mattress is the right size and has been filled correctly.



Placing the limbs or other objects between the moving parts of bed may cause damage or accident.



Only medical mattresses are allowed. Using other types of mattresses may cause damage to the bed.

## 8.2. PREPARING FOR START

Prior to using the bed for the first time:

- Ensure the bed and all accessories are at room temperature.
- Ensure the bed has been cleaned and disinfected (see section 11).
- Ensure the power cable is plugged appropriately.
- Ensure the brakes on the castors have been applied.
  - **Note:** Before locking the wheels, make sure that they are parallel to the length of the bed and inwards – they cannot pose a tripping risk.
  - **Note:** All four wheels should be locked to eliminate the accidental movement of the bed. If the bed will be used in a tilted position, it is recommended to unlock wheels from the foot bed end to prevent the wheels from rubbing against the floor when tilting. After reaching the required position of the mattress platform's tilting, block the wheels again.
- Ensure the bed is level, on the flat surface and all electrical functions controlled by handset work properly.
- Ensure the handset's functions are locked/unlocked (depending on the assessment of the patient's condition and the environment – see section 8.5.3).



Note, if the electrical functions do not operate ensure the handset has been 'unlocked' (see section 8.5.3).

Two bed ends (made of powder-coated steel) support the mattress platform, electrical system and a set of side rails to ensure patient's safety. The safe working load is 215 kg.

The bed is equipped with 4 lockable wheels to allow manoeuvring the bed. However, the bed is not intended for transport of the patient. The bed can be disassembled into four separate parts that can be installed on transport stand delivered along with the bed – for easy transport and storage.

### 8.3. BRAKE SYSTEM

The bed has 4 braked castors.

- To apply the brakes: Press the brake pedal down.
- To release the brakes: Lift the brake pedal up.

For safety reasons, wheels should be blocked with the foot (not with the use of a hand), and the manufacturer recommends wearing adequate footwear.

During normal use, all wheels should be locked – wheels at the foot bed end should be unlocked when using the tilt function.

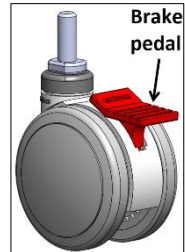

### 8.4. SIDE RAILS AND MATTRESSES

Taurus Junior bed comes as a standard with a full length side rails. Wooden rails extend over the entire length of the bed.

#### 8.4.1. MATTRESS THICKNESS



- With standard length side rails the approved mattress height is from 115 to 140 mm.
- Side rails must only be used with proper size and type mattresses approved for use with Taurus Junior bed.
- The use of side rails that have not been approved for use with the bed is unacceptable due to the risk of loss of health or life.

#### 8.4.2. OPERATING THE SIDE RAILS

##### To lower side rails:

- Lift the side rails gently upwards.
- Press the release button for side rails.
- Gently lower the side rails (the release button can be let depressed when lowering side rails).

##### To raise the side rails:

- Lift the side rail until it is heard to latch into position at the top height.

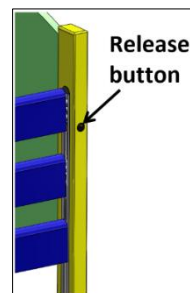



- When in the raised position, ensure the side rails are locked in place at all times in order to avoid trapping and/or injury.
- Before using side rails, make sure that no limbs or objects are placed between side rails due to the risk of trapping and/or injury, as well as damage to side rails or the bed's frame.
- Side rails are not designed to support the patient.
- Side rails are not designed to be used as a patient's lifting aid.
- When operating the side rails ensure they are free from obstructions, to prevent injury or entrapment.
- When leaving the bed, do not hold the side rails – risk of trapping /crushing finger(s) when the weight of the patient's legs causes side rail's bending and closing the gap between side rails.



- Do not use the side rails to move the bed – the risk of damaging side rails/bed's frame.
- Do not use side rails as a positioning and/or lifting aid – the risk of damaging side rails and/or the bed.
- When lowering do not drop the side rail.

## 8.5. ELECTRICAL OPERATION

Taurus Junior bed has been equipped with a 9-button easy to use handset. It is intended for use by both the patient and the caregiver. However the handset should be operated by the care person. During the operation of the bed position by the caregiver, make sure that the user is informed about the change in the position of the mattress platform.

Thanks to the use of the handset, it is possible to control the electronic, linear system of actuators, which are controlled by the central control box. Actuators are attached to moving parts of the bed's frame. This enables to change their position with the use of the handset. Pressing the appropriate button activates the selected function, and releasing completes the operation and stops all movements. The caregiver has the option of blocking the bed's functions (if necessary) in order to reduce the risk of accidental and/or unintentional operation of the bed. The caregiver is responsible for determining whether the patient is mentally and physically able to operate the bed's functions with a minimal risk of injury or damage to the body.



- Ensure a risk assessment is undertaken to ensure the suitability of the occupant or visitor using the handset.
- The handset cable must also be considered in regards to the risk of accidental strangulation of the bed occupant or visitors – If the cable introduces an unacceptable risk it is



recommended that the handset is removed from the bed.

- Before lowering the bed ensure nobody is in close proximity to the underside of the bedframe – Risk of crushing.
- Before lowering the bed ensure feet / limbs are kept away from the castor pedals / yellow corner posts - Risk of crushing.
- It is forbidden to use any glowing or burning objects (candles, cigarettes, etc.) in the bed's area – the risk of damage to the electrical system leading to a fire.
- It is forbidden to use actuators in the presence of flammable gases and/or in oxygen-rich environments due to the risk of explosion/fire.



If the bed is continuously used for an extended period of time and it exceeds the duty cycle the control box and / or lift actuators may become temporarily disabled or irreparably damaged. If this occurs remove the power supply from the wall and allow system to rest for 20-30 minutes before attempting to re-operate

#### 8.5.1. HANDSET LOCATION

The handset and its cable shall be stored in a secured location out of reach of the child\*. Storage location of handset is labelled by a marking as shown on the picture. For compliance with the instruction consider additional purchase of lock box (see section 16).

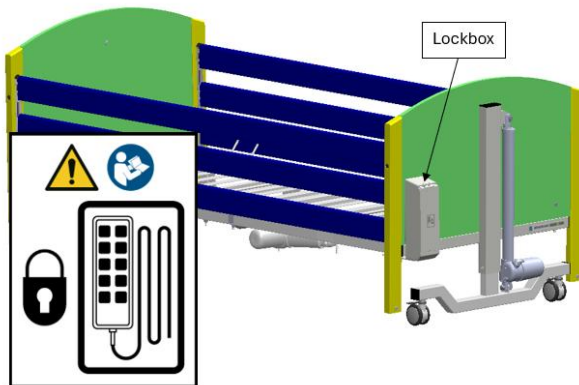

The manufacturer recommend that the handset is positioned on the handset holder, facing inwards and with all functions locked out when the patient is left unattended to minimise the risk of unauthorised operation and accidental strangulation.

## 8.5.2. 9-BUTTON HANDSET OPERATION

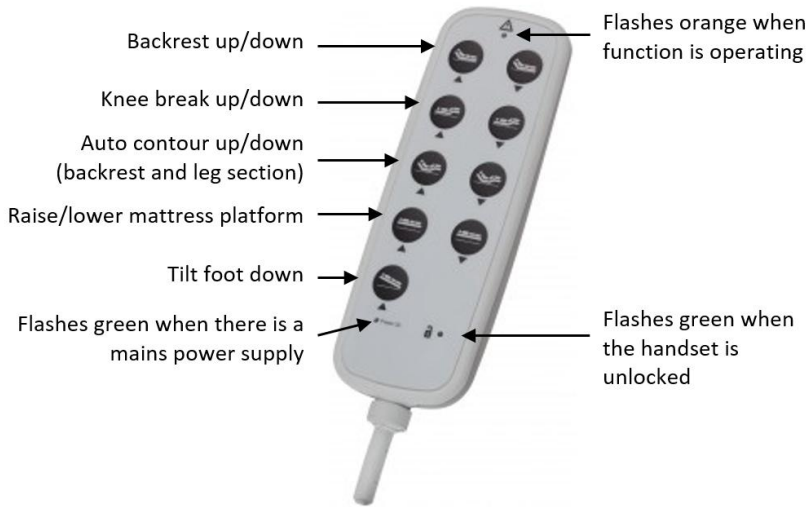

Note: when the bed is in the tilt position, levelling the mattress platform is carried out through the adjustment of the mattress platform high, by lifting the platform upwards (maximum value) or lowering down (maximum value) – until the mattress platform is levelled.



- Engage the lockout function if a patient could be injured due to inadvertent motion of the mattress platform.
- If children, adults with learning difficulties or even pets pose a potential risk of intentional or unintentional tampering with the bed the lockout function on the handset is to be used at the discretion of the carer.
- Consideration is to be taken in the storage of the handset lockout key to minimise the risk of it being swallowed by a baby, child or the bed occupant and creating a choking hazard.
- Consideration is to be taken in the location of the handset lockout key to minimise the risk of unauthorised users changing the lock setting.

### 8.5.3. HANDSET LOCKOUT

The handset is supplied with a lockout function which enables the care person to disable the handset with a mechanic key (attached to the bag with Instructions For Use) until the light is on / off. The use of the handset lock function depends on the caregiver's decision.



**To lock / unlock the handset:** turn the handset over, put the key in the recess on the back of the handset, turn the key (fully) clockwise to lock or counter clockwise to unlock functions.

Note: Functions should be disabled when the bed is put into service.



Consider locking the handset function if a patient may be injured due to unintentional movement of the mattress platform.

### 8.6. LEG SECTION

Note: The operation of the leg section is dependent on the position of the ratchet as detailed below.

The bed is fitted with an adjustable leg section. When the leg section function on the handset is operated the height or angle of the leg section is adjusted, depending on whether or not the leg section ratchet is set.

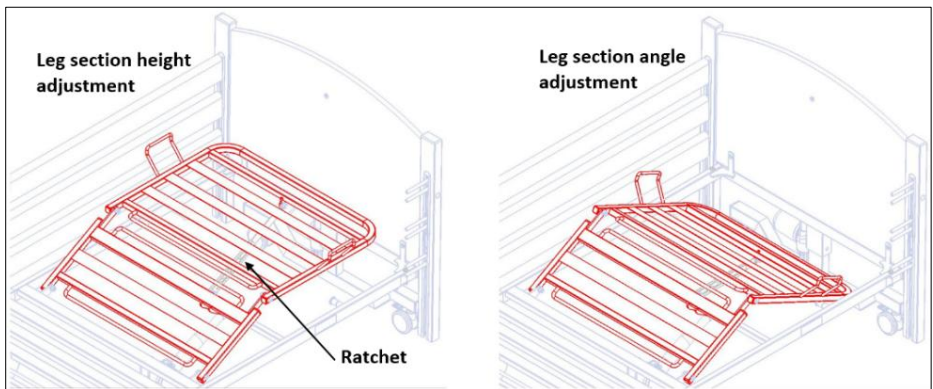

**Setting the bed so that the leg section height adjustment operates:**

- Press the leg section button on the handset and raise to maximum height.
- Lift the leg section manually with the use of handles so that the ratchet engages (once engaged the leg section will be supported by the ratchet).
- The leg section will now move parallel to the bed frame as it is driven up / down with the use of the adequate function on the handset.

- Lowering the lower leg section to the lowest position will automatically reset the ratchet's setting.

**Setting the bed so that the leg section angle adjustment operates:**

- Press the leg section button on the handset and raise the leg section (height not important).
- Lift the foot section manually so that the ratchet disengages (if in doubt lift the leg section to the ratchet's maximum extent).
- Gently lower the leg section down.
- The leg section angle adjustment will now be set.
- To unlock (reset) the ratchet, use handles to lift the thigh section to the maximum position.



Before attempting to lift the leg section either:

- Ensure there is no load on the foot section, or
- Support the foot section with a second able bodied person.



The leg section is only to be used for the lifting of a patient's legs – Any other use may damage the bed frame.

## 9. ASSEMBLY ONTO THE TRANSPORT STAND

---



- Before attempting to assemble the bed onto the transport stand ensure these instructions have been read and fully understood.
- Ensure a risk assessment in line with local health and safety policy is undertaken to ensure that staff are not put at risk when performing assembly activities.
- Take care when assembling the bed onto the transport stand, the sections are of considerable weight (see section 15.1).
- It is advisable to assemble the bed with a second able bodied person.

### Side rails

- Raise / lower the bed to approximately its middle height - make sure that the mattress's platform is levelled.
- Raise the side rails to its highest position.
- Remove the retaining screw from one of the channels.
- Lower the side rails at this end with care until the finger assembly disengages from the channel.
- Carefully remove all side rails.
- Relocate the finger assemblies into the channel (see section 6.4).
- Re-fit the retaining screw into the channel.
- Repeat for the other side of the bed.

### Electrics

- Flatten and lower the bed and the whole mattress platform to its minimum height.
- Unplug the mains cable from the mains socket.
- Using a flat-headed screwdriver remove the retaining clip from the control box.
- Unplug the high / low, leg section actuator and handset cables from the control box.
- Neatly wrap all cabling around the relevant bed sections.

### Bed Frame

- With cable ties (or similar), secure the moving parts of the backrest and leg section to the bed frame halves.
- Release the brakes from the castors.
- Loosen the grub screws in the middle of the bed frame.
- Whilst supporting both halves of the bed frame, split the bed in half and gently lower onto the floor.
- Unfasten the grub and dome screws from one end of the bed.

- Whilst supporting the bed end pull the platform half away and gently position both sections on the floor / against a wall.
- Repeat for the remaining half of the bed.

### Assembling onto the Stand

- Position both transport stand brackets onto one bed end, taking care to ensure the brackets are both orientated in the correct direction.
- **Tighten both hand wheels on each side.**
- Insert opposite bed end onto both transport stand brackets.
- **Tighten both hand wheels on each side.**
- Lock the castors.
- Loosen the hand-wheel on the vertical tube on the transport stands.
- Before lifting backrest and leg sections, make sure that moving parts are secured with cable ties, stretch foil, tape, etc.
- Carefully lift the backrest section and lower the spigots into the open tubes, ensuring the electrics are facing inwards.
- **Tighten the hand-wheel on the transport stands.**
- Carefully lift the leg section and lower the open end onto the vertical bars, ensuring the electrics are facing.
- **Tighten the grub screws on the leg section frame.**
- Ensure all cabling is neatly wrapped around the relevant bed sections and is not dragging on the floor or is under excess tension and the instructions for use and the actuator cable retaining clip are safely stored.

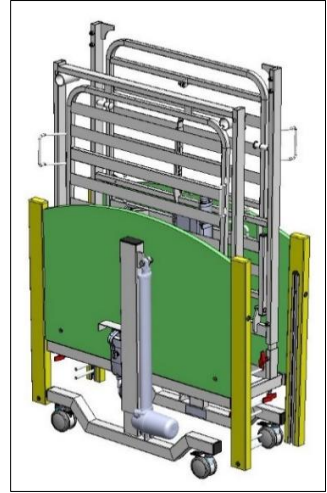

- The bed must never be moved on the transport stand with the hand wheels or grub screws being loose / missing and any of the movable section is not secure immovable. The risk of the bed collapsing.
- Make sure that moving parts were secured with cable ties, stretch foil (etc.) – the risk of uncontrolled movements of individual sections during transport.
- During transport hold only the constant parts of bed construction.

## 10. POWER FAILURES

---

The Taurus Junior bed is not equipped as standard with an additional emergency power supply (Battery Backup System (ECS)) that enables lowering of the backrest and leg sections in the event of a power failure. A bed fitted with a standard control box does not allow battery installation; a dedicated control box equipped with a socket for two 9V batteries must be ordered instead.

Emergency systems allow a limited number of movements (raising and lowering) in emergency situations, depending on the battery charge level or condition, as well as on the type of bed and the load applied. If the bed is not equipped with an additional emergency power supply, in the event of a power failure the electric functions of the bed will not operate, resulting in the backrest and/or leg sections and the position of the mattress platform remaining in the last used position (e.g. raised).

The Battery Backup System (ECS) is an additional emergency power supply system integrated with the ECS control box. In the event of a mains power failure or outage, the system allows control of the bed functions for a limited period of time. Bed functions may operate more slowly due to battery power.

### 10.1. EMERGENCY LOWERING BACKREST AND LEG SECTIONS

The backrest and knee break are operated via two individual actuators that are located underneath the mattress platform. In the event of power failure and the need to lower please follow the steps below:

- If either the backrest or leg section is raised, locate the actuator supporting the relevant section.
- Address another person for assistance in holding the relevant section.
- Remove the pin that holds the bolt in place (**only on one side!**).
- Remove the bolt that holds the actuator (**only on one side!**).
- Remove the piston by placing it gently on the floor – it can hang down.
- Gently lower the section to the level position

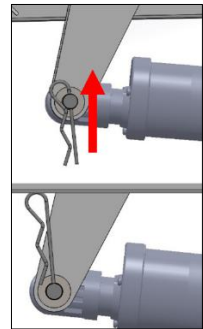

Warning

- If the section should be lowered while the patient is in the bed, a risk assessment consistent with local health and safety regulations ought to be carried out in order to determine if it is possible to levelled the section with the load in a safe way.



- **When the pins are removed there is nothing supporting the section, the person holding the frame must be ready to support the section weight.**
- It is recommended that 2 persons perform the operation.
- Beware of objects and body parts crushed between the bed headrest and platform frameworks.

## 11. DECONTAMINATION

---

Infection control and routine cleaning must be carried out in accordance with the Infection Control Policy, the local infection control schedule or recommendations from the local regulatory authorities.



- Always disconnect the bed from the main power supply prior to cleaning.
- Ensure all ports on the electrical system (control box and actuators) have cable plugs inserted to maintain the IP rating.
- Regular cleaning and disinfection of the bed frame and relevant accessories will help to prevent the risk of infection to the occupant and / or carer.
- Prior to transferring the bed frame / accessory to another user ensure it has been cleaned and disinfected using the method as detailed below to help prevent the risk of cross infection.
- Before and after any type of servicing, maintenance, technical inspection, or repair, the bed and its accessories must be thoroughly cleaned and disinfected in accordance with applicable infection control procedures.

Before the beginning of disinfection and cleaning operations it is advisable to remove any accessories that are fastened to the bed.

These instructions apply to all accessories (with the exception of mattresses).

### General Cleaning:

- The bed should be cleaned by starting with the cleanest parts of the bed and systematically moving to the dirtiest parts. Extra care should be taken around areas where excess dirt or dust may gather.
- The cloth should be changed during the cleaning process if it becomes soiled.
- Wipe down with a clean cloth moistened with a mild detergent and dilute with warm water (40°C).
- Gently wipe all surfaces with cold, clean water and immediately dry them with a dry cloth – they should be completely dry before being used again.

### Decontamination:

- Mop up any fluid with paper towels.
- Wipe bed down using cold clean water.
- Wipe down with a 0.1% Chlorine solution (1,000 ppm) in cold water.
- Gently wipe all surfaces with cold, clean water and immediately dry them with a dry cloth – they should be completely dry before being used again.

- Always ensure the cleaned parts are allowed to dry before putting the mattress back in place.

In cases of blood spills or other bodily fluids it is recommended that a 1% Chlorine solution (10,000 ppm) is used instead. Ensure fabric surfaces are rinsed with clean water after application.

Note: If any of the stages stated above are omitted or combined it will reduce the effectiveness of the clean.

Note: The use of neat bleach or similar surface cleaners is not recommended as damage may be caused to the cleaned surfaces.



- During decontamination use appropriate protective cover to minimize contact of these measures with the skin. Always check what neutralizing agent is recommended by the manufacturer.
- Decontamination procedure performed by an unauthorized person pose a threat to the person as well as the environment.
- The bed manufacturer assumes no responsibility for any loss or damage caused by improperly conducted decontamination.
- Pay special attention to the decontaminator does not get into the electronic system, sockets and other electrical components - the possibility of a short circuit.

## 12. MAINTENANCE

---

Only authorised service personnel or RehaBed service engineers should carry out repairs or service activities. The manufacturer is not liable for unauthorised repairs. Failure to observe the rule may result in the manufacturer's warranty becoming void. Service activities may be performed by any trained person or service personnel. **The bed must be serviced annually, as a minimum.**

The manufacturer also recommends that the care person performs frequent visual and operational inspections. If there are any signs of damage or the bed is not performing as it should, it should be withdrawn from service until the bed has been repaired and is fit for use again.

Periodically check to ensure that:

- No parts are missing.
- All fixtures and fittings are tight.
- No parts show signs of excessive wear (including no cracks near welded areas).
- The electrical components display no sign of damage - If so turn off at the mains and remove the bed from use immediately.
- The frame is mechanically operational.
- The bed operates as per its intended purpose.
- The bed is cleaned following the guidelines in this Instruction Manual.
- All accessories and additional equipment are fitted in a right way.

### 12.1. GENERAL MAINTENANCE

The manufacturer recommends that the beds are serviced **once yearly, as a minimum**. Please act accordingly with the following instructions:



- Failure to perform inspections at the recommended frequency could adversely affect the basic operation of the bed and (consequently) put the patient at risk.
- Always disconnect the bed from the main power supply prior to performing any maintenance procedures (with the exception of checking electrical functions of the bed).
- Modification of the bed frame is not allowed without the permission of the manufacturer or Drive DeVilbiss Healthcare Ltd. - A hazard could be introduced.
- The bed should be vacated by the patient before any maintenance or inspection takes place. If this is not possible due to the patient's mobility, care should be taken for the service engineer not to make contact with the patient when working on electrical items.



- Electrical system components are only to be replaced by authorised service personnel or a Drive DeVilbiss Healthcare service engineer.
- Only manufacturer approved components, specified for the Taurus Junior bed, should be used - if in doubt contact your local distributor, importer or manufacturer.
- Never attempt to re-wire any components.

- Check if all electrical functions operate correctly.
- Check if all electrical cables are in good condition.
- Check if the mains cable and plugs are in good condition, if either is damaged it must be replaced as a complete assembly, the plug or cable must never be re-wired.
- Check if cover protecting the actuator plugs and the power cable plug in the control box is fitted.
- Check if all nuts, screws and fasteners are tight and that none are missing or incomplete.
- Check if all grub screws and knobs are present.
- Check if the backrest section is mechanically operational.
- Check if the leg section (including the knee break functions) work correctly.
- Check if all labels and stickers are present and legible.
- Raise and lower the side rails. Check that they move smoothly.
- Check that aluminum channels at the bed ends operate correctly.
- Check that the lock on the side rails automatically engages when raised.
- Check that the castors lock function works correctly and that when locked castors do not move.
- Check if the bed's frame does not show signs of excessive wear (in particular whether there are no cracks near welds).
- If any gaps appear to be outside of specification remove the bed from use until the dimension of the gap in question has been confirmed.

If in doubt about correct replacement of a component contact your local distributor. Refer to the parts list for part codes and assembly detail. Copies are available from your local distributor.

## 12.2. SERVICE LIFE

The service life of the Taurus Junior bed is 10 years\*, with the exception of the mattresses. On the basis that the bed and its associated accessories are serviced and maintained in acceptance with the information detailed in these instructions for use and the individual instructions provided with the accessory in question.

The service life of accessories is also subject to specification. The lifting pole with handle has an expected service life of 10 years, provided it is used correctly. In the case of mattresses, the service life is specified in the manufacturer's product sheet.

At the end of service life, the bed should be withdrawn from use in accordance with local waste management policy.

\*Not applicable to the electrical components – see section 15.4.

### 12.3. FAULTY FINDING

Listed below are a set of electrical faults that may occur within the service life of the bed. If a fault does occur please try the following suggestions, as these may help in diagnosing the fault, or contact the service department.

<b>Fault</b>	<b>Possible cause</b>	<b>Remedy</b>
<b>Electrical functions do not work</b>	Functions locked out on handset	Unlock functions with a mechanical key (see section 8.5.3)
	Mains cable not plugged into the control box or socket	Check to see if the 'power on' light on the handset is on and the mains cable is plugged in at both ends
	Fuse blown in the mains plug	Check to see if the 'power on' light on the handset is on, if not turn off the device, unplug the mains cable and contact the approved service department
	Actuator / handset cables not plugged in	Check plug connections on the control box
	Damage to mains cable, actuator cable or handset cables	Turn off the device, unplug the mains cable and contact the approved service department
	Work cycle of the control box has been exceeded – possible permanent damage	If the control box has exceeded its duty cycle permanent damage may have occurred. Allow power supply to cool for 20-30 minutes before attempting to re-operate. If electrical functions still do not work a replacement power supply and/or control box will be required
<b>Electrical functions working slow</b>	Heavy load on the bed	Remove load
<b>Incorrect functions operate while controlling the handset</b>	Actuator plugs are plugged into the bad ports in the control box	Check that the connected cables correspond to the markings on the control box – correct connection is described in section 6.3
<b>The bed instable</b>	Grub screws loose	Tighten grub screws



During the adjustment and maintenance attention should be paid to ensure that no part of the body is found in the potentially hazardous section (movable: headrest section, leg section, high / low system, side rails).

### 13. DISPOSAL OF PARTS

---

When the bed frame / electrical system has come to the end of its useful life follow local recycling and W.E.E.E. (Waste Electrical and Electronic Equipment) policies.

The electrical system on the bed frame is not to be disposed of in general municipal waste. Some of the electrical components could be harmful to the environment and where viable the components can be recovered and reused / recycled.

The steel, plastic and wooden components are also to be separated and disposed of following the local recycling policy as these can also be recovered and recycled.



The bed is to be decontaminated before disposal to avoid risk of cross contamination.

## 14. ELECTROMAGNETIC COMPATIBILITY (EMC)

---

The electrical system has been designed to meet the necessary EMC requirements (IEC 60601-1-2 standard) however it may still be affected by or emit harmful radio frequency (RF) energy. The RF emissions from the electrical system are very low and are not likely to cause any interference to nearby electronic equipment, however interference to sensitive equipment is still possible. Likewise, if the immunity limits of the electrical system are exceeded the system may be seen to operate abnormally.

Interference can be received from fixed transmitters (e.g. commercial radio and television towers) and portable / mobile RF communications equipment (e.g. mobile phones). Due to the increasing number of mobile phones and other wireless devices the possibilities of interference to the electrical system and other surrounding equipment results in the need for special precautions to be taken regarding EMC.

If the bed or any alternative equipment is found to be operating abnormally turn off the piece of equipment that is believed to be causing the interference (if possible) to identify the source of the RF energy. Once identified mitigation measures are to be taken, such as the separation distances being increased and / or the device(s) being re-orientated.

If the bed continues to operate abnormally turn off at the mains supply and contact your local distributor or importer.



- The bed should not be used adjacent to or stacked with other medical electrical equipment, where viable. If adjacent or stacked use is necessary, the bed and associated medical electrical equipment should be observed to verify normal operation - If not taken into account abnormal operation could occur.
- The use of accessories and cables other than components specified or provided by the manufacturer may increase the electromagnetic emission of the bed and cause malfunction.
- Portable RF communications equipment (including peripheral devices – such as antenna cables and external antennas) should not be used closer than 30 cm from any part of the bed (including cables). Otherwise, performance may be deteriorated.

## 15. SPECIFICATION

### 15.1. BED DATA

		TAURUS JUNIOR	TAURUS JUNIOR LOW
Overall length		2080 mm	2080 mm
Overall width		930 mm	930 mm
Mattress platform height		390-810 mm	280-700 mm
Under bed clearance (to underside of frame)		355 mm	255 mm
Under bed clearance (to underside of actuator)		212 mm	127 mm
Mattress platform length		1900 mm	1900 mm
Mattress platform width		780 mm	780 mm
Backrest section tilt		0 - 74°	0 - 74°
Thigh section tilt		0 - 34°	0 - 34°
Maximum lower leg section height		138 mm	138 mm
Reverse Trendelenburg position tilt		0 - 12°	0 - 12°
Part Weights	Leg rest platform	18 kg	18 kg
	Backrest platform	18 kg	18 kg
	Head end	18,9 kg	18,5 kg
	Foot end	18,9 kg	18,5 kg
	Side rails	15 kg	15 kg
Overall Bed weight		89 kg	88 kg
Overall bed weight on the transport stand (excluding side rail)		76 kg	75 kg

The bed data identify the maximum angles which can be achieved in normal use by each part of the mattress support platform with reference to horizontal. Mattress platform height is defined as the maximum and minimum height from the floor which can be achieved by the mattress support platform in normal use.

### 15.2. MAXIMUM LOAD

Safe working load	215 kg
Maximum User weight	178 kg

The safe working load is the sum of the weight of: patient/user, mattress, accessories, loads carried by accessories (excluding the patient's weight).



The above-listed maximum loads refer to a bed used by one person only. The bed is not designed to carry the weight of guests seated at the side of the bed. Additional weight can damage components or make the bed unstable – creating a risk of injury.

### 15.3. TECHNICAL DATA OF SIDE RAILS

Taurus Junior bed has been tested and approved with wooden side rails along the entire length of the mattress platform. The table below presents the basic dimensions of side rails that can be used with the bed.

	Length [mm]	Heigh [mm]	Width [mm]
Taurus Junior Side Rail	1886	85	28

The manufacturer recommends the use (only) the manufacturer's side rails along with their beds. The manufacturer does not recommend the use of Taurus Junior bed with side rails for patients with a height of less than 125 cm – the equipment supplier is responsible for ensuring the suitability for use.



- Despite the fact that the manufacturer made every effort to ensure that the design of side rails meets the appropriate safety standards, side rails may still pose a potential risk of death resulting from entrapment and/or suffocation.
- Persons responsible for the sale/purchase, selection for use and adjustment of side rails, should be aware of the potential risk regarding entrapment and/or suffocation when the bed is in use.
- When positioning and adjusting the side rails, make sure that all spaces between side rails, mattress and bed frame will not block the patient's head and body. Furthermore, the size and physiological condition of the patient should be considered. Conduct an assessment in order to ensure that the gaps between side rails are not large enough to create a potential risk of entrapment and/or suffocation. All persons responsible for the patient care must be aware that increased vigilance is required when a patient lies on the bed with side rails.



Only medical mattresses may be used. The use of other types of mattresses may damage the bed.

## 15.4. ELECTRICAL DATA

	Power supply plug	Control unit
Voltage in:	100 - 240V, 50/60Hz	24-29V DC
Current in:	2A max	8A max
Standby power:	≤ 0.5W	-
Electric shock protection:	Class II	Class III
Duty cycle:*	10% <b>2 mins</b> of continuous use followed by <b>18 mins</b> not in use. 5 switching cycles per one minute	

\*Electrically operated beds are intended to be operated intermittently rather than continuously. If the bed is operated continuously for up to 2 minutes it must then be left for at least 18 minutes before reuse to allow the electrical system to cool sufficiently. If the bed is continuously used for an extended period of time and it exceeds the duty cycle the control box may become temporarily disabled or irreparably damaged.

No more than two drives may be operated at rated load simultaneously!

Safety standards: IEC 60601-1: 2005  
IEC 60601-2-52:2009  
IEC 60601-1-11:2010

Applied part electrical shock protection: Type BF

Applied parts: Mattress platform  
Profiling sections  
Bed ends  
Handset  
Side rails

Liquid ingress protection: IPX4 - Splash resistant

Noise level: 67dB(A)

Service life: 5 years\*

Environmental conditions:

	Operational Limits**	Transportation/storage limits
Ambient temperature:	+10°C to +40°C	-20°C to +50°C
Humidity:	30% - 75%	30% - 75%
Atmospheric pressure:	800 to 1060 hPa	800 to 1060 hPa
Altitude:	≤ 2000 m	≤ 2000 m

\* After 5 years, electronic components should be serviced or replaced to ensure safe operation for up to 10 years.

\*\* Always ensure the bed is brought up/down to room temperature before plugging in and operating. It is recommended to leave the bed for at least 2 hours in order to ensure that it reaches room temperature.

## 16. ACCESSORIES

The Taurus Junior bed has been tested and approved with the following accessories:

- Medical mattress 780mm x 1900mm
- Lifting pole
- Lockbox

Characteristics of the accessories can be found in the relevant accessory's instructions for use. The manufacturer cannot be held responsible for any injury or incident which relates to the use of any product combinations not approved by the manufacturer. It is the carer's responsibility for selecting and fitting the products correctly and ensuring that the product combination is compatible. In the case of doubts, please contact the supplier or the manufacturer.



- The manufacturer is not responsible for any injuries or incidents connected with the use of unapproved accessories.
- It is forbidden to use accessories that have not been approved or are not intended for use with the bed – the risk of danger due to incompatibility regarding the combination of products.

### 16.1. MATTRESSES AND SIDE RAILS

Taurus Junior bed has been tested and approved with listed above mattresses. The mattresses listed above are mattresses recommended by the manufacturer. Contact your local distributor, importer or manufacturer to select a mattress suitable for your bed.

Mattresses have been tested and approved with side rails characterized by specific dimensions dedicated to the Taurus Junior bed (see section 15.3).

	<b>Length</b>	<b>Width</b>	<b>Thickness</b>
Foam mattresses*			
ControlCare 1	1900 mm	780 mm	120 mm
ControlCare 2			120 mm
ControlCare 3			140 mm
ControlCare 4			150 mm
ControlMaxCare			160 mm
Waffle mattress			140 mm
Waffle mattress with HR filling			120 mm
			140 mm
			150 mm
			180 mm

*\*It is possible to order a custom-size mattress.*



- Mattresses and side rails not approved by the manufacturer pose a risk of entrapment for the bed user.
- The manufacturer deems the listed above foam mattresses to be suitable for use with the Taurus Junior side rail, however a patient risk assessment must be performed to ensure the gap between the top of the mattress and top of the side rail when fully lowered is acceptable and will not introduce a hazard to the patient when entering/exiting the bed.
- Make sure that the applied mattress is characterized by the correct size and type and that it is positioned in a right way on the bed. The mattress should be placed between mattress holders on sides of the mattress platform sections – an incorrect mattress may pose a risk of entrapment and/or fall of the patient.
- Make sure that side rails and mattress are correctly selected – incorrect selection of products may pose a risk of entrapment.

## 16.2. LIFTING POLE

Optionally, the bed may be equipped with a lifting pole with a triangular handle and an adjustable strap length. To install the lifting pole:

- Lock all four castors.
- Select one of the two lifting pole sockets located in the corners of the mattress platform (on the head bed end side).

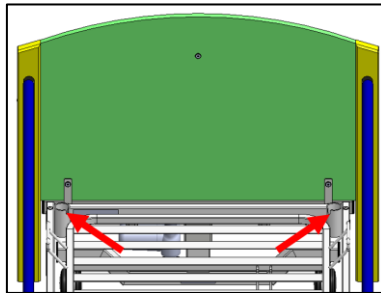

- Insert the lifting pole into the selected socket. **Note:** Ensure that the positioning pin is correctly aligned with the positioning slot.
- Attach the adjustable strap with the triangular handle to the lifting pole. Ensure that the strap is positioned between the locating pins.

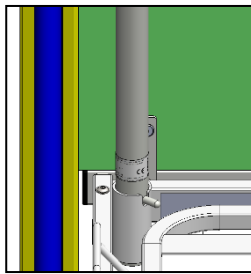
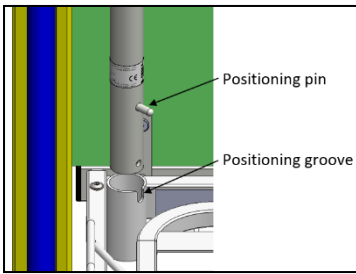

- Installation of the lifting pole in a location not intended for this purpose may result in injury or an accident.
- To ensure user safety, make sure the lifting pole is correctly and securely installed before use.



Warning

- Installation of the lifting pole **in a place that is not intended for this purpose** poses a risk of damage to health or an accident.
- In order to ensure the user's safety while using the lifting pole, make sure that the lifting pole has been properly installed.

### 16.3. LOCKBOX

To mount the lockbox onto the bed frame:

1. Use an Allen key to untighten the original screws which are located on the left side of the bed end.

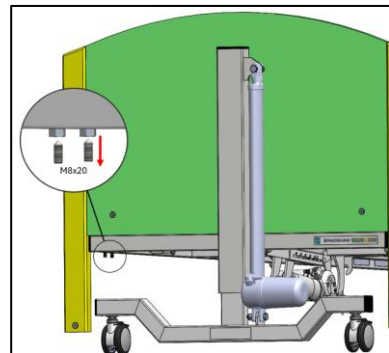

2. Replace them with M8x30 grub screws which are included in the lockbox mounting set.

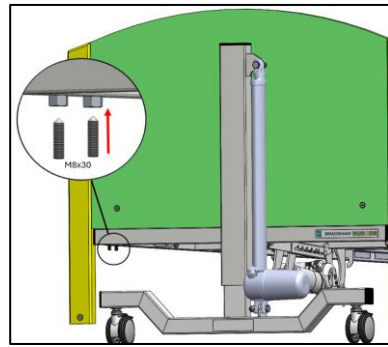

3. Position the lockbox in the required spot on the bed frame, ensuring it fits securely and is aligned to bed end.

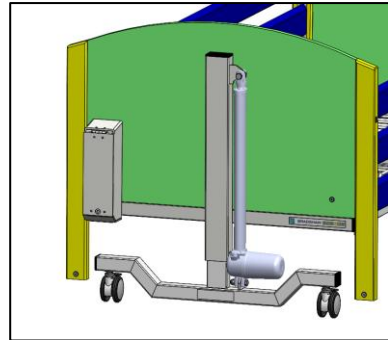

4. Insert the two 2x M8 plain nuts onto M8x30 grub screws and tighten them.

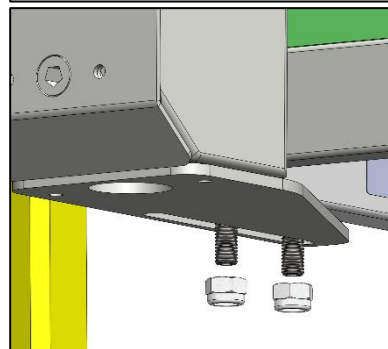

5. Make sure the plain nuts are fastened as tight as possible.

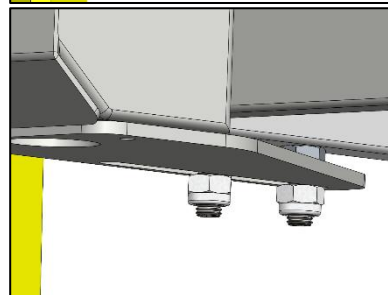

## 17. WARRANTY

---

The warranty period is 24 months from the date of purchase of the bed. This warranty does not cover mechanical damage and interference in the structure, actuators and control box of the bed. In the absence of regular maintenance, the guarantor is not liable for resulting damage (see the Maintenance and inspections section). You can find Guarantee Card at the end of this Instruction Manual.

### 17.1. WARRANTY TERMS AND CONDITIONS

1. Reha bed sp. o. o. ensures the smooth operation of medical device for 24 months from the date of sale, in accordance with the technical-operating conditions described in the instruction manual.
2. At the time of fault recognition or defects within the warranty period, they shall be repaired free of charge within 14 working days from the date of notification and making the product available for repair.
3. The User has no obligation to deliver the advertised product of weigh over 10 kg and oversized (e.g. area of over 3m<sup>2</sup>)
4. If the User fails to deliver the product along with a claim, set out in section 3, the complaint period shall be calculated from the date of the inspection of the advertised product.
5. Warrantor is exempt from liability for damage to the product which resulted from improper use or use not compliant with the instructions (e.g. storage, maintenance, breaking the seals, mechanical damage).
6. The concept of repair is not synonymous with the operations mentioned in the instruction manual, which the user is obliged to perform on one's own.
7. The warranty shall be extended by the period in which the product is under repair. In the event that the complaint procedure shall not detect a fault as a defect subject to the warranty, all costs associated with the transport / the approach, the work of a service engineer and the costs of spare parts and materials shall be covered by the purchaser (holder of the product).
8. Wear and tear as well as ongoing maintenance of the product (e.g. cleaning, tightening the set screws, the activities provided in the instruction manual) are not subject to warranty.
9. Warranty does not cover screws, nuts deficiencies etc., resulting from failure to perform maintenance.
10. Replacing the advertised goods or part thereof to a new one, free from defects, does not extend the warranty period.
11. The product handed in for repair should be cleaned. Cleaning is not included in warranty maintenance works. If the product has not been handed in already cleared, Manufacturer reserves the right to invoice the services associated with decontamination of the product, or not perform warranty repair and return the product at the expense of the claimer.
12. The loss of the warranty occurs in the following cases:

- a) Product identification based on the serial number and production date on the bed label is not possible,
  - b) The product has been used not according with the instruction manual, it was used for other purposes or in other conditions than those for which it was intended,
  - c) There has been an alteration to the product, including the repair of the product by anyone other than the Manufacturer or a service company authorized by Reha bed sp. z o. o.
  - d) The product has been damaged mechanically (e.g. fall, hit, breaking, leaning or resting on side rails, etc.)
  - e) Product damage occurred as a result of environmental factors such as pollution, flooding actuators or control box, use in unsuitable conditions, and if the product has been damaged due to the user' fault (e.g. the use of a damaged product or inadequate equipment and bed overload, etc.)
  - f) The product has been used, despite the occurrence of faults,
  - g) The product has been damaged during transport,
  - h) The product supplied for repair is not complete,
  - i) Failure to adhere with cautions and warnings in the instruction manual.
13. Consideration of the claim applies only to products placed on the market by the Manufacturer RehaBed sp. z o. o.

## 18. REPAIRS AND SERVICING

---

<b>DATE</b>	<b>DESCRIPTION</b>	<b>SERVICING COMPANY SIGNATURE AND SEAL</b>





**REHA-BED Sp. z o.o.**  
ul. Spacerowa 1  
41-253 Czeladź  
phone (+48 32) 346 00 33  
fax. (+48 32) 346 00 34  
biuro@rehabed.com.pl

**INSTRUC/TR-JUNIOR/EN, 2026/03 REV9**