

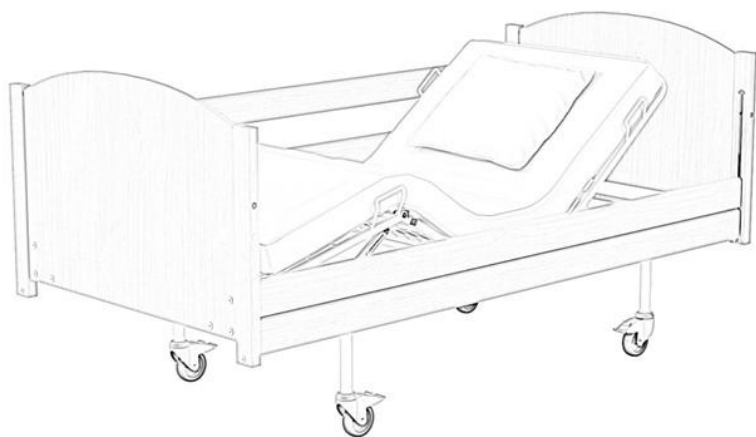

INSTRUCTIONS FOR USE

ARIES



WELCOME TO REHA-BED

Reha-Bed is a Polish family company specializing in the production of the highest-quality rehabilitation beds and a wide range of products that support the care, rehabilitation, as well as long-term and short-term care.

Thanks to the fact that we not only produce and design our equipment but also are very flexible and can adapt to the requirements of our clients. Thanks to over 15 years of experience in the industry, we can advise our clients with full responsibility and help them to choose the most optimal equipment.

We meet the needs of our clients, search innovative solutions and constantly strive to expand our offer.

Reha-Bed Sp. z o.o. places the greatest emphasis on the high quality of components and materials used in production. It takes advantage of extensive experience and knowledge of world-class suppliers of actuators, driving systems and fasteners. The dynamically developing technology of our company ensures the highest quality of steel and wooden elements for the produced assortment. Precise control of our products is a guarantee of the future satisfaction of our clients.



R&D Department

Engineers, designers and constructors responsible for development, improvement and expansion of the range of products.



Production Department

Our production is based on modern world-class equipment and experience of our employees.



Employment

Over 50 qualified employees employed in the production department.



Area

Warehouse and production halls, as well as office space with a total surface exceeding 4500m².

CONTENTS

1. INTRODUCTION.....	4
1.1. CONTACT	4
1.2. TO WHAT IT CONCERNS?	4
1.3. FEATURES	4
1.4. USE	5
1.5. CONTRAINDICATIONS.....	5
2. WARNINGS AND CAUTIONS	7
2.1. GENERAL WARNINGS	7
3. TRANSPORT AND STORAGE.....	10
4. SYMBOL DEFINITIONS	12
5. PARTS	14
5.1. PARTS SPECIFICATION	14
6. BED ASSEMBLY AND PREPARING FOR USE	15
6.1. ASSEMBLING THE MATTRESS PLATFORM	15
6.2. ASSEMBLING THE WOODEN BED ENDS ..	16
6.3. FITTING THE WOODEN, FULL-LENGTH SIDE RAILS.....	16
6.1. ASSEMBLING THE MEDICAL BED END	18
6.2. FITTING THE MEDICAL SIDE RAILS	18
6.3. CHECKING THE BED.....	19
7. TRAINING.....	20
8. FIRST USE.....	21
8.1. OPERATIONAL LIMITS.....	21
8.2. GENERAL SAFETY.....	21
8.3. PREPARING FOR START	22
8.4. BRAKE SYSTEM.....	23
8.5. SIDE RAILS AND MATTRESSES	23
8.5.1. MATTRESS THICKNESS.....	24
8.5.2. OPERATING THE WOODEN, FULL- LENGTH SIDE RAILS	24
8.5.3. OPERATING THE MEDICAL SIDE RAILS	24
8.6. EMERGENCY PULLING-OUT OF THE BED END.....	25
8.7. OPERATING THE BACKREST SECTION	26
8.8. LEG SECTION.....	26
9. DISASSEMBLING THE BED FOR TRANSPORT	28
10. DECONTAMINATION	30
11. MAINTENANCE.....	32
11.1. GENERAL MAINTENANCE	32
11.2. SERVICE LIFE	33
11.3. FAULTY FINDING.....	34
12. DISPOSAL OF PARTS	35
13. SPECIFICATION	36
13.1. BED DATA	36
13.2. MAXIMUM LOAD.....	36
13.3. TECHNICAL DATA OF SIDE RAILS	36
14. ACCESSORIES	38
14.1. MATTRESS AND SIDE RAILS	38
14.2. LIFTING POLE	40
15. WARRANTY	42
15.1. WARRANTY CONDITIONS	42

1. INTRODUCTION

Thank you for your trust and purchase of our product. Before using the bed, please read this instruction manual carefully and make sure it is fully understood. In the case of any doubts concerning the installation, use or maintenance of the bed, please contact the seller or the manufacturer.

1.1. CONTACT

In order to get help with the installation, use or service of the product, as well as to report an unexpected operation or to obtain any information regarding service, warranty, sales or customer service concerning this product, please contact your seller, distributor or (in case of doubt) with Reha-Bed Sp. z o.o. at the following address:

Reha-Bed Sp. z o.o.
Spacerowa 1 Street
41-253 Czeladź
Poland

In service matters (including spare parts):

e-mail address: serwis@rehabed.com.pl

phone: +48 519 842 766

phone: +48 608 727 090

Other issues:

e-mail address: biuro@rehabed.com.pl

phone: +48 608 727 090

Each serious incident connected with the device should be reported to Reha-Bed Sp. z o.o. and the competent authority of the Member State, where the device is used. Please provide the product serial number (SN) in all correspondence. You can find it on the identification labels, which are located on the inside of the backrest section frame and the leg section frame, as well as on the bottom of each bed ends.

In order to receive support outside of Poland, please contact the local distribution company, which sold you the device.

1.2. TO WHAT IT CONCERNS?

This instruction manual applies to Aries beds with mechanically operated backrest and knee break.

All products are CE marked – in accordance with the Regulation (EU) 2017/745 on medical devices (MDR).

1.3. FEATURES

- 4 separate sections (movable back and leg section) or 2 separate sections (movable back section only)
- Mechanical adjustment of the backrest section or backrest and leg section
- Constant mattress platform height

- Wooden side rails along the entire length of the mattress platform or steel medical side rails (Aries MED only)
- Mattress platform filled with steel mesh
- Pull-out bed end (Aries MED only)

1.4. USE

The Aries bed has been designed to provide the user with optimal independence and freedom whilst aiding the manual handling requirements of the carer. The Aries bed is intended for use within domestic environment, in long-term care facilities, where medical care and health monitoring are required (e. g. nursing homes, rehabilitations centres, geriatric wards).

The bed significantly relieves a caregiver thanks to a fully mechanically profiled platform that enables to adjust the position to the user's needs.

The bed is designed for users with a minimum height from 146 to 185 cm, BMI greater than 17 and a maximum weight up to 178 kg. The lower (or upper) age limit is not defined. The usability of the bed depends on the physical size of the patient in relation to the various proportions and spaces around the bed's frame. It is not intended for patients weighting less than 40 kg.

The bed is intended for one person only!

The bed is designed to support the patient's weight (as described above) while sleeping or resting. It assists in the care and/or ensures comfort for the patient or caregiver – when the bed is used in long-term care facilities.

It is the carer's responsibility to determine that the patient is both mentally and physically capable of occupying the bed with minimal risk of personal injury.



- A risk assessment must always be performed on the suitability of the patient to the bed frame and any ancillary accessories.
- **If there are any doubts to use the product should be consulted with a health care professional (e.g. physiotherapist, doctor). Make sure the product is suitable for your condition or dysfunction.**

1.5. CONTRAINDICATIONS

The contraindications for using the Aries bed include:

- Cervical or skeletal traction,
- Level of mental development that makes it impossible to safely operate the bed's functions – if the bed functions remain unlocked,
- Confusion, agitation or unstable emotional state of the patient – if side rails are installed and/or they are in the highest position,
- Exceeding the maximum patient's weight,

- Inadequate height of the patient (below 146 cm or above 185 cm),
- Inappropriate BMI of the patient (below 17),
- Inadequate weight of the patient (less than 40 kg).

Consider the presence of other contraindications that are specific for the patient of the care environment.

2. WARNINGS AND CAUTIONS



Warnings in this instruction manual indicate potential hazards, disregard of which could lead to injury or death.



Cautions in this instruction manual identify potential hazards, disregard of which could result in damage to the equipment.

2.1. GENERAL WARNINGS



- **READ THE INSTRUCTION MANUAL CAREFULLY** before use or installation.
- The user is obliged to observe this instruction.
- The bed is to be installed and put into service in accordance with the information provided in these instructions for use.
- The bed should be used in acceptance with its intended purpose.
- The bed is not suitable for children. If used by a child, ensure that a risk assessment has been conducted – taking into account the child’s proportions and the dimensions of the bed’s frame.
- The bed is not suitable for users with a height less than 146 cm – in case of doubt, please contact the local distributor, importer or manufacturer.
- The bed is not suitable for users weighting less than 40 kg – in case of any doubt, please contact the local distributor, importer or manufacturer.
- The bed is not suitable for users with a BMI less than 17 - in case of any doubt, please contact the local distributor, importer or manufacturer.
- Accessories that have not been designed for use with the bed should not be used.
- The use of additional mechanical or electrical devices that are not intended for use with the bed is unacceptable.
- Only original spare parts supplied by the manufacturer are allowed.
- The bed cannot be used if any screws/parts are missing.
- During transport, hold only the constant, massive parts of the bed ends!
- During assembly / disassembly and regular operation, particular attention should be paid to the risk of hand injury.



- Start and use of the defective device that could pose a risk to patients or others is forbidden.
- The bed should be used and kept away from heat sources and open flames (e. g. cigarettes, electric fire, heaters, etc.) – risk of fire.
- Make sure that there are not many sockets under the frame – liquids that may seep into such a socket during normal use of the bed may pose electrical/fire hazard.
- The place of use of the bed there should be no obstacles to the proper operation or installation.
- Setting up and using the bed should be on flat, horizontal surfaces so that all the castors touch the ground.
- Before each use, check the bed and lock all four wheels.
- Wheels should be locked/unlocked by foot, not by hand.
- In the absence of supervision of the patient (if such circumstances occur), the bed should be set to the highest position of railings on both sides of the bed. Unlocking and lowering them can be done only by the person responsible (care person or nurse).
- The bed is not intended for patient's transportation. The manufacturer allows moving the bed with patient within the room to clean or gain access to the patient. The transportation should take place while maintaining the patient in the horizontal lying position.
- Side rails must be installed on both sides of the bed (on the side of the wall as well).
- Standard height side rails enable to use mattresses with a maximum height of 140 mm.
- The height extension of the side rails enables to use mattresses with a maximum height of 260 mm.
- Side rails may only be used with proper size mattresses intended for the bed – otherwise there is a risk of the user entrapment.
- Leaning against or resting on rails may cause accidents!
- Leaning out of the bed is a threat of injury!
- Do not exceed the safe working load of the bed!
- In case of damage to the rails (bending, breaking, cracking etc.), they should be immediately replaced with new ones due to the risk of an accident.
- Placing limbs between the moving elements of the bed may cause injury and accidents.
- During the adjustment and maintenance attention should be



paid to ensure that no part of the body is found in the potentially hazardous section (movable: backrest section, leg section, side rails) - risk of injury to the limbs!

- Particular attention should be paid to small children, the patient's limb or other items around the bed that could entrap in a space between mattress platform and the chassis and be damaged or injured.
- Do not sit on the raised sections of the back, thigh and lower leg.
- Bear in mind that self-repair poses a risk of accidents or damage to the bed!
- Maintenance, repair and disinfection may be conducted only by specially trained persons.
- It is forbidden to modify the bed's frame without the consent of the manufacturer – this poses a risk of danger.
- Precautions are to be taken when routing cables from external equipment around the bed to ensure that they do not become squeezed, trapped or damaged - risk of electric shock and/or fire.
- All electrical components that are related accessories, which are damaged, must be immediately withdrawn from service and replaced – damaged electrical components may present a risk of electric shock/fire.
- If the bed will be used with a hoist, make sure that there is enough space under the bed– risk of crushing of the bed's frame.
- Due to the small space under the bed, special attention should be paid to young children, user limbs and other items around the bed that could be trapped between the bed's components and injured or damaged.
- Deformed lifting pole should be promptly replaced.
- **ALL THE ABOVE WARNINGS AND CAUTIONS SHOULD BE STRICTLY ADHERED TO.**

3. TRANSPORT AND STORAGE

The following conditions should be followed when transporting and storing the bed:

- Bed always to be stored on a flat and level floor.
- Side rail components (not including wooden side rails) to be kept in the aluminum channels on the bed ends (or stored safely together).
- Wheel brakes should be applied.
- All profiling sections secured with hook and loop tape (or similar).
- Make sure that all fasteners (such as screws, washers, plugs, etc.) are carefully tightened and secured for transport.
- Covered to protect from fluid ingress, dirt, dust etc.
- Beds must not be stored one on top of another.
- Beds not to be stored on their side.

Environmental conditions:

	Operational Limits	Transportation/storage limits
Ambient temperature:	from +10°C to +40°C	from -20°C to +50°C
Humidity:	30% - 75%	30% - 75%
Atmospheric pressure:	from 800 to 1060 hPa	from 800 to 1060 hPa
Altitude:	≤ 2000 m	≤ 2000 m



- The bed is not intended for patient transport, it is not to be moved out of the room it is located in with a patient occupying the bed - Risk of patient / carer injury. If the bed is to be moved within the room with an occupant in the bed a risk assessment in line with local health and safety policy is to be undertaken in order to ensure that neither staff or patients are put at risk when moving the bed; this is dependent on the situation and load on the bed.
- If transporting the bed ensure a risk assessment in line with local health and safety policy is undertaken to ensure that staff are not put at risk when moving the bed, especially in regards to moving up / down inclines and uneven surfaces.
- The bed should not be transported if any screws are missing or sections are not secured - risk of the bed collapsing.
- In order to prevent the risk of cross contamination, when removing the bed from its place of use by the end user, make sure that all actions (connected with the bed) are carried out with the use of disposable gloves. Next to, properly dispose the glove, unless it can be verified that the bed and all accessories have been properly disinfected and cleaned.



- If the bed is removed from its place of use by the end user, before handing the bed over for storage, make sure that the bed has been cleaned and disinfected – in acceptance with your local infection control rules and/or rules that are specified in this instruction manual (see section 10).



- Avoid exposing the bed to direct sunlight – direct sunlight may cause bed's colour fading over time (including the fading of the bed's labels).
- Avoid placing the bed in a humid environment – a long-term exposure to moisture may have a detrimental effect on parts of the bed's frame.
- Wooden and wood-based elements are not waterproof. Exposing the product to moisture, flooding, or prolonged dampness constitutes use contrary to the operating instructions and may lead to permanent damage to the product. Cleaning and disinfection must be carried out in accordance with the information contained in this operating manual.
- During use, natural changes in the wood may occur, such as cracking, color changes and fading of the impregnation, knots falling out, or resin exudation. These result from the properties of the material and the influence of external factors, including UV radiation and environmental conditions.
- Differences in shade within a single wood color result from the natural non-uniformity of the wood structure and do not constitute a product defect or grounds for a complaint.
- Do not use side rails to transport the bed – risk of damage.
- Do not transport the bed over threshold – risk of damage.
- When using the bed's functions, make sure that no furniture or other things (such as a bedside table) are not an obstacle.
- Make sure that the bed is positioned in an appropriate distance from walls/other furniture in order to prevent the damage to the equipment when operating the bed (especially when working with a tilted mattress platform).
- Cable tiles, etc. used for storage should be removed after assembling the bed, before use – the frame may be damaged in the event of their leaving.

4. SYMBOL DEFINITIONS

The following symbols are observed on the beds:



Warning
Beware of potential hazard



Cautions
Beware of potential hazard



Refer to instructions for use – recommended
Failure to read the instructions for use could introduce a hazard



Refer to instructions for use – mandatory
Failure to read the instructions for use could introduce a risk



Maximum patient weight
Refer to section 13.2



Safe working load
Refer to section 13.2



Marking of the medical device

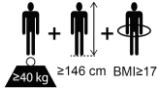

Determination of minimum physical requirements for adults
From the left: minimum patient weight, minimum patient height, minimum BMI value of the patient



Mattress suitability
Refer to section 14.1



Warning – knee break intended purpose
Knee break to be used for lifting patient legs only

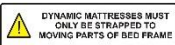

Warning – dynamic mattress
Dynamic mattresses must only be strapped to moving parts of bed frame



Warning – removable side rail
Incompatible and improperly installed side rails may pose a risk of injury or death - see the instruction manual



Total product weight in transport mode

Heavy weight of the product - be careful when transporting on the transport stand and assembly



Certification mark

Product meets the requirements of the Regulation (EU) 2017/745 on medical devices (MDR)



Manufacturer data



DOM

Date of manufacturing



SN

Serial number



Reference number

Product code

5. PARTS

5.1. PARTS SPECIFICATION

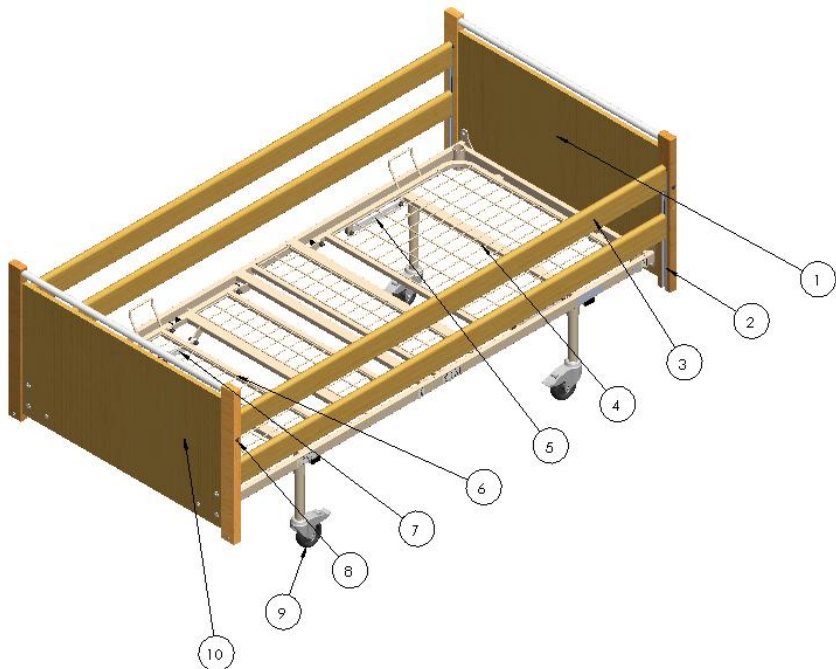

(The figure shows the Aries bed with wooden side rails)

1. Head end
2. Side rail channel (aluminum channel)
3. Wooden side rail
4. Backrest mattress platform
5. Backrest section ratchet
6. Leg section mattress platform
7. Leg section ratchet
8. Side rail release button
9. Castor
10. Foot end
11. Lifting pole (optional, not visible)



Warning

- During assembly / disassembly and regular operation, particular attention should be paid to the risk of hand injury.
- The bed cannot be used in case a screw is missing.

6. BED ASSEMBLY AND PREPARING FOR USE



- Before attempting to assemble the bed, ensure these instruction manual has been read and fully understood.
- Ensure a risk assessment in line with local health and safety policy is undertaken to ensure that staff are not put at risk when performing assembly activities.
- Pay special attention during assembly activities due to the heavy weight of individual elements.
- The manufacturer recommends that the bed should be assembled by two persons.

6.1. ASSEMBLING THE MATTRESS PLATFORM

- Fit the castors by sliding them into the sleeves in the back frame and leg frame. Tighten the set screws located in the wheel sleeves (4 pcs.)

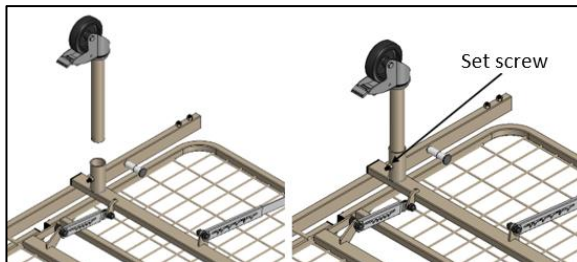

- Release the brakes in two castors in one mattress platform.
- Determine the position of the set screws at the bottom of the mattress platform frame, and then connect the backrest mattress platform frame with the leg mattress platform frame by sliding the connector into the frame. Tighten the set screws (4).

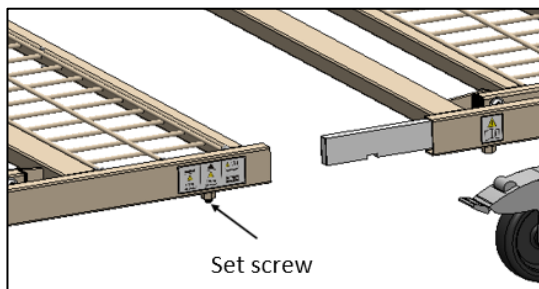

- Cut off/remove the plastic retaining ties/Velcro straps from the head and foot mattress platforms.



The bed cannot be used if any of the set screws or locking screws is missing – the risk of the bed's collapsing.



Make sure that all packaging parts that secure movable sections (such as cable ties, foils, tapes, etc.) have been removed before the bed is put into service – otherwise, there is a risk of damaging the bed's frame.

6.2. ASSEMBLING THE WOODEN BED ENDS

- **Note: If this action is being undertaken the manufacturer recommend that the castors are braked before assembly commences.**
- Fit bed end sliding the spigot into the platform end and determine the position of the dome head screws and set screws.
- Tighten all set and dome head screws, making sure the set screws are tightened before tightening the dome head screws.
- Repeat for the other bed end.

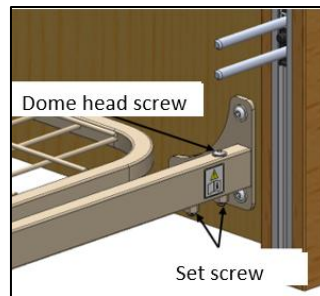
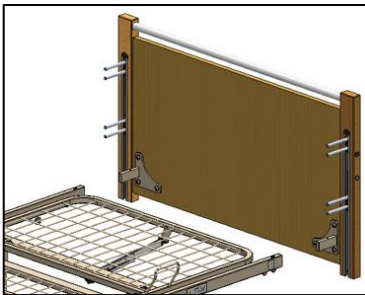

The bed cannot be used if any of the set screws or locking screws is missing – the risk of the bed's collapsing.

6.3. FITTING THE WOODEN, FULL-LENGTH SIDE RAILS

Before installation, make sure that the length of side rails is suitable for the length of the mattress's platform (see section 13.3).

- Depress each end's side rail release button (see section 8.5.2) and lower the finger assemblies to the bottom of the channel

- On the foot end, remove the retaining screw at the bottom of the side rail channel on one side. **Do not remove head end retaining screws.**
- Remove the finger assembly from the channel.
- Take two side rails (rounded face pointing upward) and slide the end of them into set of fingers that is still located in the channels at the head end of the bed. Carefully rest the unattached ends on the floor taking care to ensure that the other ends are sufficiently far into the fingers so that they will not fall out.

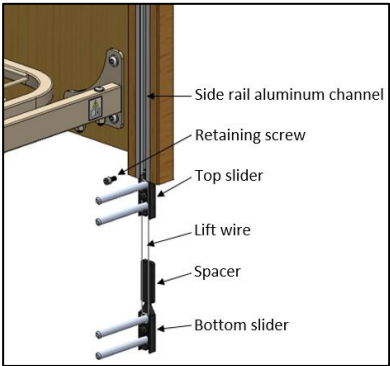

- Take the previously removed finger assembly, place the lift wire over the top finger set (as shown in the picture below) and insert into the other end of the top side rail. Slide the finger assembly inside the channel. **It is recommended that a second person holds the rail at this point.**

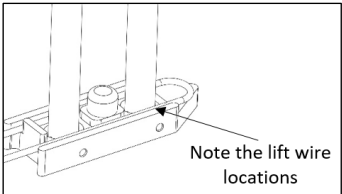
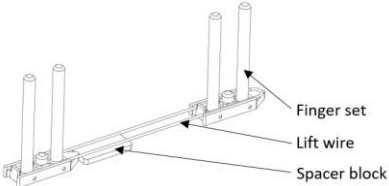

- Whilst holding the top side rail, slide the plastic spacer block into the channel and place the upper finger of the bottom finger set through the hole in the lift wire (as shown on below picture) and into the other end of the lower side rail and lift the assembly until a click is heard.
- Re-fit the previously removed retaining screw. This ensures that the side rail finger assembly cannot fall out of the channel when in the lowered position.

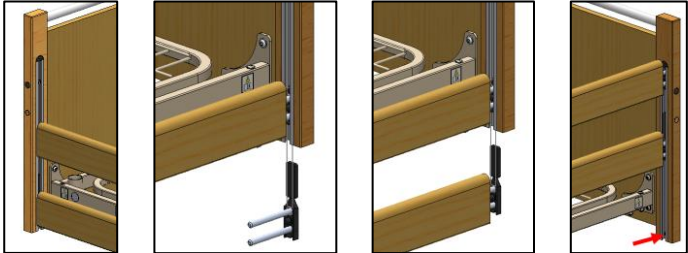

- Repeat the assembly process for the side rails on the other side of the bed.
- Check that the side rails function properly and smoothly. Check that the side rails easily lock into the highest position to make sure that they are mounted in a right way.



- If there is any doubt about the assembly contact the provider or manufacturer, incorrectly fitted side rails can lead to death.
- Side rails must be installed on both sides of the bed (on the side of the wall as well).
- With standard side rails, the maximum height of the mattress is 140 mm.
- In case of damage to the rails (bending, breaking, cracking etc.), they should be immediately replaced with new ones due to the risk of an accident.

6.1. ASSEMBLING THE MEDICAL BED END

- Place the bed end in the mounting sockets by inserting the tubes evenly.
- It is recommended to hold the bed end in the places pointed by the red arrows during the assembly.
- Repeat the above steps for the other bed end.

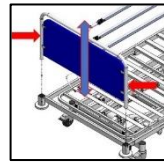

The bed cannot be used if any of the set screws or locking screws is missing – the risk of the bed's collapsing.

6.2. FITTING THE MEDICAL SIDE RAILS

To fit the side rails follow the below instructions:

- Insert the side rail's pivots into the mounting bush in the mattress platform (as shown on the right).
- The side rails should be placed evenly into both mounting bushes.

Note 1: Make sure that the side rails release button is positioned near to the foot end.

Note 2: The medical side rails are available in the right and left version!

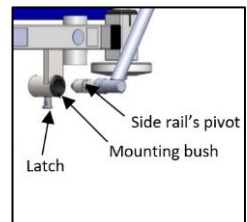

- Ensure that the latches lock the side rail in place.



- If there is any doubt about the assembly contact the provider or manufacturer, incorrectly fitted side rails can lead to death.
- Side rails must be installed on both sides of the bed (on the side of the wall as well).
- With standard side rails, the maximum height of the mattress is 140 mm.
- In case of damage to the rails (bending, breaking, cracking etc.), they should be immediately replaced with new ones due to the risk of an accident.

6.3. CHECKING THE BED

The bed is now fully assembled. Before the bed is put into use ensure the bed is correctly assembled:

- Ensure the correct side rails are fitted to the bed, refer to section 13.3.
- Are the set and dome screws on all 4 corners of the bed fully tightened (only for the bed with wooden bed ends)?
- Are the retaining screws for the side rails mechanisms inside the aluminium channel fully tightened (only for the bed with wooden side rails)?
- Has all packaging been removed, e.g. cable ties securing the platform sections?
- Is the bed clear of obstructions?
- Do the side rails raise / lower smoothly and lock automatically in the raised position?
- Has a risk assessment been performed on the suitability of the bed (and any ancillary equipment) for the user?
- Has the bed (if necessary) been cleaned and disinfected before use?

In order to find details about the side rails and the mattress see section 14.1



The bed cannot be used in case any screws are missing.



Make sure that all retaining straps have been removed from any bed parts. If not, the bed can be damaged.

7. TRAINING

Professional personnel should be appropriately familiarized with the functionality of the bed, its limitations and the target user group before use. The user's ability to operate the handset in an independent manner should be determined in acceptance with the risk assessment. The user should be familiarized with the handset and the functionality of the bed by a trained person as soon as possible – preferably before the use of this product. It is the responsibility of the end user to ensure they have received sufficient training to use the bed and any associated accessories safely and correctly.

It is the responsibility of the trained person to ensure that users are able to use this bed and any additional accessories in a safe and proper way. If the above-mentioned instructions are not sufficient and additional training is required, please contact your local provider or producer (see section 1.1), who is authorized to discuss training options.

8. FIRST USE

Prior to using the bed for the first time the following risk assessment must be performed based on the status of the patient and their body. This assessment should include, but is not limited to:

- The possibility of patient entrapment
- Fall out of bed
- The possibility of interference from children (and adults)
- Patients with learning disabilities
- Unauthorized persons
- Physical and mental condition of the patient
- Housing conditions
- Use of side rails and other accessories



- After assembling the bed, there should be no unused parts. However, the presence of spare parts (pins, holder, screws, etc.) should be taken into account to minimize the risk of ingestion by the patient, who use the bed and/or other persons – risk of choking.
- Prior to each operating the bed ensure the brakes on all the castors have been applied.
- It is forbidden to start and use the product with defects that may pose a risk to users or other persons.
- If children, adults with reduced cognitive/learning abilities or (even) pets pose a potential risk of intentional or unintentional manipulating the bed, consider its suitability for use during the initial risk assessment of the patient/product.

Two bed ends (made of powder-coated steel) support the mattress platform and a set of side rails to ensure patient's safety. The safe working load is 215 kg. The bed is equipped with 4 lockable wheels to allow manoeuvring the bed. However, the bed is not intended for transport of the patient. The bed can be disassembled into four separate parts – for easy transport and storage.

8.1. OPERATIONAL LIMITS

- Ambient temperature: +10°C to +40°C
- Humidity: 30% - 75%
- Atmospheric pressure: 800hPa to 1060hPa (altitude ≤ 2000m)

8.2. GENERAL SAFETY

- When the bed is operated, make sure that objects such as a bedside table or other furniture are not an obstacle.

- Before exploiting the bed, make sure that the patient has been positioned correctly.
- Keep distance of min 15 cm from the walls.
- If the bed is being used in conjunction with a hoist ensure the under bed clearances are sufficient - risk of frames clashing.
- Make sure that every used mattress is the right size and has been filled correctly.



Placing the limbs or other objects between the moving parts of bed may cause damage or accident.



Only medical mattresses are allowed. Using other types of mattresses may cause damage to the bed.

8.3. PREPARING FOR START

Prior to using the bed for the first time:

- Ensure the bed and all accessories are at room temperature.
- Ensure the bed has been cleaned and disinfected (see section 10).
- Ensure the brakes on the castors have been applied:
 - **Note:** Before locking the wheels, make sure that they are parallel to the length of the bed and inwards – they cannot pose a tripping risk.
 - **Note:** All four wheels should be locked to eliminate the accidental movement of the bed.
- Ensure the bed is level, placed horizontally, on the flat surface so all the castors touch the ground and all mechanical functions work properly.



- Before operating the bed ensure the patient is positioned appropriately ensuring all limbs are clear of moving parts.
- Ensure that any mattresses used are of the correct size and type and have been fitted correctly – Incorrect mattress specification could lead to an entrapment and / or falls hazard.
- Ensure the mattress is compatible with the side rails (if fitted).



- Only medical mattresses are allowed. Using other types of mattresses may cause damage to the bed.
- Ensure the bed is positioned an appropriate distance from walls / other furniture to prevent damage or patient injury when operating the bed (particularly when operating it in tilt).

8.4. BRAKE SYSTEM

The bed has 4 braked castors. The individual lock enables locking a single, selected castor.

- To apply the brakes: Press the brake pedal down.
- To release the brakes: Lift the brake pedal up.

For safety reasons, wheels should be blocked with the foot (not with the use of a hand), and the manufacturer recommends wearing adequate footwear.

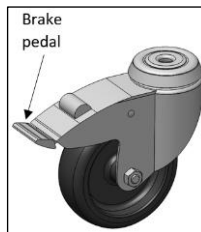

During normal use, all wheels should be locked.



- Castors should be locked / unlocked by foot, not by hand.
- If the bed is to be pushed up / down a slope it is advised that two people move the bed, with one person at each end.
- If the bed is to be pushed with a heavy load it should be assessed whether or not two people should move the bed, this is dependent on the situation and load on the bed.

8.5. SIDE RAILS AND MATTRESSES

Aries bed comes as a standard with a full length side rails. Wooden rails extend over the entire length of the bed. Additionally, you can order a height extension to wooden rails.

Characteristics of the mattresses and the side rails tested and approved by the manufacturer can be found in the section 14.1.

Manufacturer only recommends the use of manufacturers side rails with this bed. Manufacturer does not recommend the use of the Aries bed and side rails when caring for individuals who are less than 146cm in length - It is the equipment provider's responsibility to ensure suitability for use.



- Whilst every care has been taken to ensure that the design of the side rails meet the relevant safety standards, beds fitted with side rails can still pose a potential risk of death from entrapment and asphyxiation.
- All staff responsible for the purchase, selection for use, and adjusting of bed side rails should be aware of the potential risk of entrapment and asphyxiation when a bed is occupied.
- Care must be taken when positioning and adjusting bed side rails to ensure that any spaces between the bed side rails, mattress or bed frame will not allow entrapment of the occupant's head or body. In addition, consideration should be



given to the size and physiological condition of the occupant and an assessment undertaken to ensure that the spacing between the bars of the bed side rails is not wide enough to present a potential risk of entrapment and asphyxiation. All staff responsible are to be aware that increased vigilance is required when nursing patients in beds fitted with bed side rails.

8.5.1. MATTRESS THICKNESS



- With standard length side rails the approved maximum mattress height is 140 mm.
- With side rails with height extensions, the mattress maximum height is 260 mm.
- The use of side rails that have not been approved for use with the bed is unacceptable due to the risk of loss of health or life.
- Ensure that any mattresses used are of the correct size and type and have been fitted correctly – Incorrect mattress specification could lead to an entrapment and / or falls hazard.
- Ensure the mattress fitted is used with a compatible side rail.

8.5.2. OPERATING THE WOODEN, FULL-LENGTH SIDE RAILS

To lower side rails:

- Lift the side rails gently, vertically upwards.
- Press the release button for side rails.
- Gently lower the side rails (the release button can be let depressed when lowering side rails).

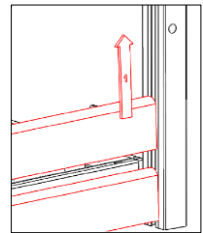
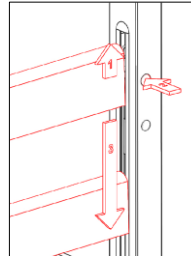

To raise the side rails:

- Lift the side rail until it is heard to latch into position at the top height.

8.5.3. OPERATING THE MEDICAL SIDE RAILS

To lower side rails:

- Pull the side rails gently towards head bed end.
- Pull the side rails release button.
- Gently lower the side rails (the release button can be let go when lowering side rails).

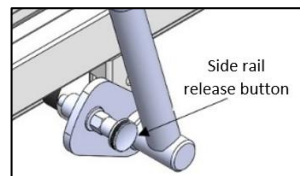

To raise the side rails:

- Lift the side rail until it is heard to latch into position at the top height.



- When in the raised position, ensure the side rails are locked in place at all times in order to avoid trapping and/or injury.
- Before using side rails, make sure that no limbs or objects are placed between side rails due to the risk of trapping and/or injury, as well as damage to side rails or the bed's frame.
- Side rails are not designed to support the patient.
- Side rails are not designed to be used as a patient's lifting aid.
- When operating the side rails ensure they are free from obstructions, to prevent injury or entrapment.
- When leaving the bed, do not hold the side rails – risk of trapping /crushing finger(s) when the weight of the patient's legs causes side rail's bending and closing the gap between side rails.
- In the absence of supervision of the patient (if such circumstances occur), the bed should be set to the highest position of side rails on both sides of the bed. Unlocking and lowering them can be done only by the person responsible (care person or nurse).



- Do not use side rails to transport the bed – the risk of damaging side rails/bed's frame.
- Do not use side rails as a positioning and/or lifting aid – the risk of damaging side rails and/or the bed.
- When lowering do not drop the side rail.

8.6. EMERGENCY PULLING-OUT OF THE BED END

The bed end of the Aries MED bed are adapted to be quickly disassembled in order to facilitate access to the patient (e.g. if intubation is necessary).

To pull out the bed end, grab the outside tube of the bed end frame, then lift the bed end up and carefully set it down on the floor.

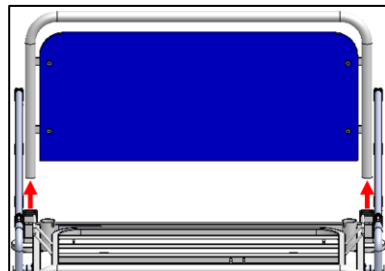

- Before disassembling / assembling the bed end, make sure that all wheels are locked.

8.7. OPERATING THE BACKREST SECTION

The operation of the backrest section is dependent on the position of the ratchet as detailed below.

- **To set the backrest section:** Lift the section manually with the use of handles so that the ratchet engages in the selected position (once engaged the backrest section will be supported by the ratchet).
- **To lower the backrest section:** Unlock (reset) the ratchet with the use of handles to lift the backrest section to the maximum position, and gently lower the section down.

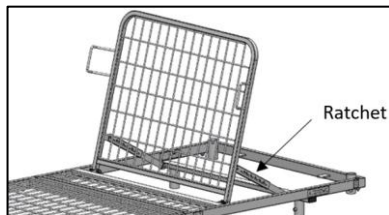

8.8. LEG SECTION

The bed can be fitted with an adjustable leg section. The operation of the leg section is dependent on the position of the ratchet as detailed below.

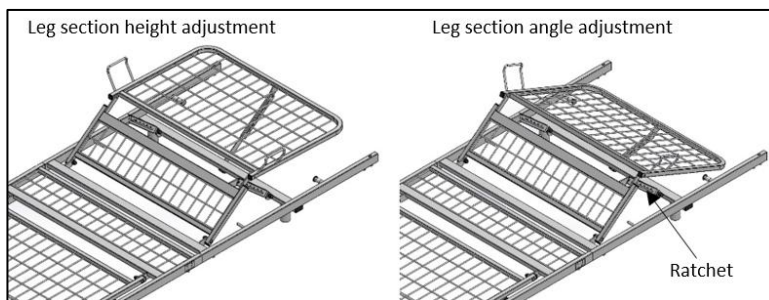

Setting the leg section:

- Lift the leg section manually with the use of handles so that the ratchet engages in the selected position (once engaged the leg section will be supported by the ratchet).
- To lower the leg section, unlock (reset) the ratchet with the use of handles to lift the leg section to the maximum position and gently lower the section down.



- Before attempting to lift the backrest/leg section either:
 - Ensure there is no load on the section, or
 - Support the foot section with a second able bodied person.
- Placing the limbs or other objects between the moving parts of bed may cause damage or accident.



- The leg section is only to be used for the lifting of a patient's legs – any other use may damage the bed frame.
- The backrest section is only to be used for the lifting of a patient's back – any other use may damage the bed frame

9. DISASSEMBLING THE BED FOR TRANSPORT



- Before attempting to disassemble the bed ensure these instructions have been read and fully understood.
- Ensure a risk assessment in line with local health and safety policy is undertaken to ensure that staff are not put at risk when performing disassembly activities.
- Pay special attention when disassembling the bed - individual sections of the bed are heavy - see section 13.1 for the weight of individual parts.
- The manufacturer recommends that the bed should be disassembled by two persons.

Wooden side rails

- Lock all 4 wheels.
- Raise the side rails to its highest position.
- Remove the retaining screw from one of the channels.
- Lower the side rails at this end with care until the finger assembly disengages from the channel.
- Carefully remove all side rails.
- Relocate the finger assemblies into the channel (see section 6.3).
- Re-fit the retaining screw into the channel.
- Repeat for the other side of the bed.

Wooden bed ends

- Unfasten 2 dome head screws above the mattress platform (near to the removed bed end).
- Loosen 4 set screws under the mattress platform (near to the removed bed end).
Do not fully remove these screws!
- Remove the bed end from spigot and put them gently aside.
- Repeat for the remaining bed end.

Medical side rails

- Lock all 4 castors.
- Raise the side rails to its highest position.
- Pull-out the latches (placed at the bottom of the mounting bushes) and pull the side rail's pivot from the mounting bushes (to prevent locking the latch).
- Repeat for the other side of the side rail.
- Carefully remove the side rail by evenly sliding the side rail's pivots out of the mounting bushes.
- Place the side rail on the floor.
- Repeat for the other side of the bed.

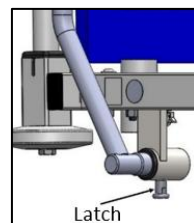

Medical bed ends

- Grab the outside tube of the bed end frame, then lift the bed end up and carefully set it down on the floor.
- Repeat for the other bed end.
- Cover the bed ends with a stretch foil, etc. to protect them from fluid ingress, dirt, dust etc.

Mattress platform

- Flatten the whole mattress platform to its minimum height.
- Use, for example, cable ties (stretch foil, tape, etc.) to secure movable parts of the backrest and leg section – any movements should be impossible.
- Unlock wheel brakes in one half of the mattress platform.
- Loosen set screws in the centre of the bed's frame.
- Hold both parts of the mattress platform, split the bed in two parts and gently lay it on the floor – consider the assistance of an additional person (if possible).
- Lock wheel brakes.
- Loosen the set screws secured the wheels in their mounting sleeves.
- Remove the wheels from the mounting sleeves.



- The bed cannot be transported if any fixing is missing, or any part of the bed is not fully secured with cable ties or similar - risk of the bed collapsing.
- Make sure that moving parts were secured with cable ties, stretch foil (etc.) – the risk of uncontrolled movements of individual sections during transport.
- During transport hold only the constant parts of bed construction.

10. DECONTAMINATION

Infection control and routine cleaning must be carried out in accordance with the Infection Control Policy, the local infection control schedule or recommendations from the local regulatory authorities.



- Regular cleaning and disinfection of the bed frame and relevant accessories will help to prevent the risk of infection to the occupant and / or carer.
- Prior to transferring the bed frame / accessory to another user ensure it has been cleaned and disinfected using the method as detailed below to help prevent the risk of cross infection.

Before the beginning of disinfection and cleaning operations it is advisable to remove any accessories that are fastened to the bed.

These instructions apply to all accessories (with the exception of mattresses).

General cleaning:

- The bed should be cleaned by starting with the cleanest parts of the bed and systematically moving to the dirtiest parts. Extra care should be taken around areas where excess dirt or dust may gather.
- The cloth should be changed during the cleaning process if it becomes soiled.
- Wipe down with a clean cloth moistened with a mild detergent and dilute with warm water (40°C).
- Gently wipe all surfaces with cold, clean water and immediately dry them with a dry cloth – they should be completely dry before being used again.

Decontamination:

- Mop up any fluid with paper towels.
- Wipe bed down using cold clean water.
- Wipe down with a 0.1% Chlorine solution (1,000 ppm) in cold water.
- Gently wipe all surfaces with cold, clean water and immediately dry them with a dry cloth – they should be completely dry before being used again.
- Always ensure the cleaned parts are allowed to dry before putting the mattress back in place.

In cases of blood spills or other bodily fluids it is recommended that a 1% Chlorine solution (10,000 ppm) is used instead. Ensure fabric surfaces are rinsed with clean water after application.

Note: If any of the stages stated above are omitted or combined it will reduce the effectiveness of the clean.

Note: The use of neat bleach or similar surface cleaners is not recommended as damage may be caused to the cleaned surfaces.



- During decontamination use appropriate protective cover to minimize contact of these measures with the skin. Always check what neutralizing agent is recommended by the manufacturer.
- Decontamination procedure performed by an unauthorized person pose a threat to the person as well as the environment.
- The bed manufacturer assumes no responsibility for any loss or damage caused by improperly conducted decontamination.

11. MAINTENANCE

Only authorised service personnel or Reha-Bed Sp. z o.o. service engineers should carry out repairs or service activities. The manufacturer is not liable for unauthorised repairs. Failure to observe the rule may result in the manufacturer's warranty becoming void. Service activities may be performed by any trained person or service personnel. **The bed must be serviced annually, as a minimum.**

The manufacturer also recommends that the care person performs frequent visual and operational inspections. If there are any signs of damage or the bed is not performing as it should, it should be withdrawn from service until the bed has been repaired and is fit for use again.

Periodically check to ensure that:

- No parts are missing.
- All fixtures and fittings are tight.
- No parts show signs of excessive wear (including no cracks near welded areas).
- The frame is mechanically operational.
- The bed operates as per its intended purpose.
- The bed is cleaned following the guidelines in this Instruction Manual.
- All accessories and additional equipment are fitted in a right way.

11.1. GENERAL MAINTENANCE

The manufacturer recommends that the beds are serviced **once yearly, as a minimum**. Please act accordingly with the following instructions:



- Failure to perform inspections at the recommended frequency could adversely affect the basic operation of the bed and (consequently) put the patient at risk.
- Modification of the bed frame is not allowed without the permission of the manufacturer - A hazard could be introduced.
- The bed should be vacated by the patient before any maintenance or inspection takes place. If this is not possible due to the patient's mobility, care should be taken for the service engineer not to make contact with the patient.
- Only manufacturer approved components, specified for the bed, should be used - if in doubt contact your local distributor, importer or manufacturer.

- Check if all mechanical functions work properly.
- Check if all nuts, screws and fasteners are tight and that none are missing or incomplete.
- Check if all screws and knobs are present.
- Check if the backrest section is mechanically operational.

- Check if the leg section (including the knee break functions) works correctly.
- Check if all labels and stickers are present and legible.
- Raise and lower the side rails – check if they move smoothly.
- Check if aluminum channels at the bed ends operate correctly (only for beds with wooden side rails).
- Check if the lock on the side rails automatically engages when raised.
- Check if the castors lock function works correctly and that when locked castors do not move.
- Check if the bed's frame does not show signs of excessive wear (in particular whether there are no cracks near welds).
- If any gaps appear to be outside of specification remove the bed from use until the dimension of the gap in question has been confirmed.

If in doubt about correct replacement of a component contact your local distributor or seller. Refer to the parts list for part codes and assembly detail. Copies are available from your local distributor or importer. Contact details can be found in section 1.1 of the booklet.

11.2. SERVICE LIFE

The service life of the Aries bed is 10 years, with the exception of the mattresses. On the basis that the bed and its associated accessories are serviced and maintained in acceptance with the information detailed in these instructions for use and the individual instructions provided with the accessory in question.

At the end of service life, the bed should be withdrawn from use in accordance with local waste management policy.

11.3. FAULTY FINDING

Listed below are a set of faults that may occur within the service life of the bed. If a fault does occur please try the following suggestions, as these may help in diagnosing the fault, or contact the service department.

Fault	Possible cause	Remedy
The bed instable	Dome head and/or set screws loose	Tighten dome head and/or set screws



During the adjustment and maintenance attention should be paid to ensure that no part of the body is found in the potentially hazardous section (movable: headrest section, leg section, high / low system, side rails).

12. DISPOSAL OF PARTS

When the bed frame has come to the end of its useful life follow local recycling policies.

The steel, plastic and wooden components are also to be separated and disposed of following the local recycling policy as these can also be recovered and recycled.



The bed is to be decontaminated before disposal to avoid risk of cross contamination.

13. SPECIFICATION

13.1. BED DATA

		ARIES 02	ARIES 03
Overall length		2070 mm	
Overall width		1050 mm	
Mattress platform height		450 mm	
Under bed clearance (up to the mattress platform)		410 mm	
Under bed clearance		390 mm	
Mattress platform length		2000 mm	
Mattress platform width		900 mm	
Backrest section tilt		0 - 74°	
Thigh section tilt		-	0 - 35°
Calf section tilt		-	0 - 24°
Maximum calf section height		-	175 mm
Part weights	Headend mattress platform	15kg	16 kg
	Footend mattress platform	17 kg	
	Bed end (each)	9 kg	
	Side rails (set)	10,5 kg	
Overall bed weight		60,5 kg	61,5 kg

Particular dimensions and weights may vary depending on the version of the bed and accessories. The bed data identify the maximum angles which can be achieved in normal use by each part of the mattress support platform with reference to horizontal. Mattress platform height is defined as the maximum and minimum height from the floor which can be achieved by the mattress support platform in normal use.

13.2. MAXIMUM LOAD

	Aries	Lifting pole
Safe working load	215 kg	80 kg
Maximum User weight	178 kg	-

The safe working load is the sum of the weight of: patient/user, mattress, accessories, loads carried by accessories (excluding the patient's weight).



The above-listed maximum loads refer to a bed used by one person only. The bed is not designed to carry the weight of guests seated at the side of the bed. Additional weight can damage components or make the bed unstable – creating a risk of injury.

13.3. TECHNICAL DATA OF SIDE RAILS

Aries bed has been tested and approved with wooden side rails along the entire length of the mattress platform and the medical side rails. The table below presents the basic dimensions of side rails that can be used with the bed.

	Length x Height x Width [mm]
Standard wooden side rails*	1986x85x28; 1986x95x28; 1986x100x28; 2175x95x28**, 2175x100x28**, 1500x498x23,5
Medical side rails (when raised)	1500x498x23,5

* The dimension depends on the selected bed option

** To be used only with bed extension.

The manufacturer recommends the use (only) the manufacturer's side rails along with their beds. The manufacturer does not recommend the use of Aries bed with side rails for patients with a height of less than 146 cm – the equipment supplier is responsible for ensuring the suitability for use.



- Despite the fact that the manufacturer made every effort to ensure that the design of side rails meets the appropriate safety standards, side rails may still pose a potential risk of death resulting from entrapment and/or suffocation.
- Persons responsible for the sale/purchase, selection for use and adjustment of side rails, should be aware of the potential risk regarding entrapment and/or suffocation when the bed is in use.
- When positioning and adjusting the side rails, make sure that all spaces between side rails, mattress and bed frame will not block the patient's head and body. Furthermore, the size and physiological condition of the patient should be considered. Conduct an assessment in order to ensure that the gaps between side rails are not large enough to create a potential risk of entrapment and/or suffocation. All persons responsible for the patient care must be aware that increased vigilance is required when a patient lies on the bed with side rails.



Only medical mattresses may be used. The use of other types of mattresses may damage the bed.

14. ACCESSORIES

The Aries bed has been tested and approved with the following accessories:

	ARIES	ARIES MED
Lifting pole with plastic handgrip	✓	✓
Bed extension (+mattress extension)*	✓	✓
Height extension (optional wooden side rail fitted up standard rails)*	✓	
Drip holder	✓	✓
Urological bag holder	✓	✓
Tablet*	✓	

* Always consult the supplier or manufacturer on the possibility of using the selected accessory with your version of the bed.

Characteristics of the accessories can be found in the relevant accessory's instructions for use.

The manufacturer cannot be held responsible for any injury or incident which relates to the use of any product combinations not approved by the manufacturer.

It is the carer's responsibility for selecting and fitting the products correctly and ensuring that the product combination is compatible. In the case of doubts, please contact the supplier or the manufacturer.



- It is forbidden to use accessories that have not been approved or are not intended for use with the bed – the risk of danger due to incompatibility regarding the combination of products.
- The manufacturer is not responsible for any injuries or incidents connected with the use of unapproved accessories.
- If the height extension for side rails is used along with a foam mattress, make sure that the patient's entry/exit is not difficult – otherwise, during the change of the patient's position, remove and reinstall the height extension (as required).

14.1. MATTRESS AND SIDE RAILS

Aries bed has been tested and approved with listed below mattresses. The mattresses listed below are mattresses recommended by the manufacturer. Contact your distributor, importer or manufacturer to select a mattress suitable for your bed.

Mattresses have been tested and approved with side rails characterized by specific dimensions dedicated to the Aries bed (see section 13.3).

Dimensions [mm] * <i>width x length x thickness</i>	
Foam Mattresses	
ControlCare 1	900x2000x120
ControlCare 2	900x2000x120
ControlCare 3	900x2000x140
ControlCare 4	900x2000x150
ControlMaxCare	900x2000x160
Waffle Mattress	900x2000x120; 900x2000x150
Waffle Mattress with HR filling	900x2000x120; 900x2000x150
Foam Mattress	900x2000x100; 900x2000x120; 900x2000x150; 900x2000x200
Foam Mattress	900x2000x120; 900x2000x150
Foam Mattress with HR filling	900x2000x150
Mattress extension	900x200x120; 900x200x140; 900x200x150
<i>* It is possible to order a custom-size mattress.</i>	

Other mattresses available upon request – contact your seller or the manufacturer to check for compatibility and suitability purposes.



Warning

- Mattresses and side rails not approved by the manufacturer pose a risk of entrapment for the bed user.
- The manufacturer deems the listed above foam mattresses to be suitable for use with the Aries side rail, however a patient risk assessment must be performed to ensure the gap between the top of the mattress and top of the side rail when fully lowered is acceptable and will not introduce a hazard to the patient when entering/exiting the bed.
- If the dynamic mattresses are used without side rail height extensions a patient risk assessment must be performed to ensure the gap between the top of the mattress and top of the side rail when raised is acceptable and will not introduce a hazard to the patient.
- If the dynamic mattresses are set to a low pressure the gap introduced by cell compression at the mattress edge and the side rail is to be considered. A patient risk assessment must be performed to ensure an asphyxiation risk is not introduced.
- Make sure that the applied mattress is characterized by the correct size and type and that it is positioned in a right way on the bed. The mattress should be placed between mattress



Warning

holders on sides of the mattress platform sections – an incorrect mattress may pose a risk of entrapment and/or fall of the patient.

- Make sure that side rails and mattress are correctly selected – incorrect selection of products may pose a risk of entrapment.



Caution

- Make sure that the control box of the dynamic mattress is not placed on side rails – risk of damage by falling when/after lowering side rails.
- It is essential that dynamic mattress straps are only attached to the moving parts of the profiling mattress platform. If the straps are incorrectly fitted around the main section of the mattress platform, serious damage could occur to various components of the bed. If in doubt contact your local provider or the manufacturer.



14.2. LIFTING POLE

Optionally, the bed can be equipped with a lifting pole with a triangular handle with an adjustable length of the belt. In order to install the lifting pole:

- Lock all 4 wheels.
- Select one of the two lifting pole sockets located at the corners of the mattress platform (on the head bed end).

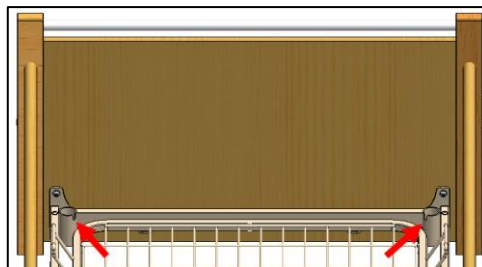

- Place the lifting pole in the selected lifting pole socket. **Note!** Make sure that the positioning pin is placed in the positioning groove.
- Place an adjustable belt with a triangle handle on the lifting pole. Make sure that the grip belt is located between positioning pins.

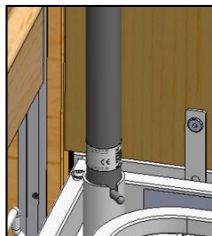
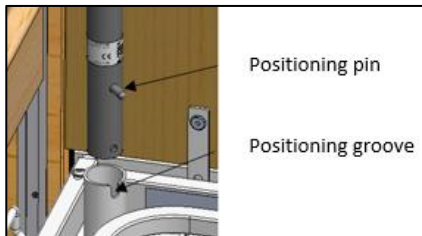

Warning

- Installation of the lifting pole **in a place that is not intended for this purpose** poses a risk of damage to health or an accident.
- In order to ensure the user's safety while using the lifting pole, make sure that the lifting pole has been properly installed.

15. WARRANTY

The warranty period is 24 months from the date of purchase of the bed. The warranty does not cover mechanical damage and interference with the bed's structure, actuators or the bed's control box. In the absence of regular inspections, the guarantor is not responsible for any damage resulting from this fact (see the Maintenance and inspections section). The warranty card is attached at the end of the instruction manual.

15.1. WARRANTY CONDITIONS

1. Reha-Bed Sp. z o.o. guarantees the efficient operation of medical equipment for 24 months from the date of purchase – in acceptance with the technical and operational conditions described in the instruction manual.
2. Upon recognition of a defect or damage to the product within the warranty period, they will be removed free of charge within 14 working days from the date of reporting and marking the product available for repair.
3. The user is not obliged to deliver the product weighting more than 1 kg and large dimensions (e. g. product's size exceeding 3m²).
4. If the user fails to deliver the product with the complaint card, the deadline for processing the complaint (set in point 3 above) is calculated from the date of inspection of the product covered by the complaint.
5. The guarantor is released from liability for damage to the product caused by inadequate use or use inconsistent with the instructions for use (e. g. storage, maintenance, broken seals, mechanical damages).
6. The concept of repair does not include actions determined in this instruction manual, which should be carried out by the user on his own.
7. The warranty is extended for the period, during which the product is under repair. If a defect (as a defect covered by the warranty) is not found during the complaint procedure, all costs connected with transport/travel, work of a service technician, as well as costs related to spare parts and materials are covered by the buyer (the product's owner).
8. The warranty does not cover wear and tear of the product resulting from its normal use and ongoing maintenance of the product (e. g. cleaning, tightening of set screws, as well as steps determined in this instruction manual).
9. The warranty does not cover missing bolts, nuts, etc., resulting from the lack of maintenance.
10. Replacement of the advertised product or its part with a new one – free from defects – does not extend the warranty period.
11. The product for the repair should be cleaned. Cleaning is not included in the scope of warranty repair work. If the product is not cleaned, the manufacturer reserves the right to invoice the service connected with the cleaning of the product or not to perform a warranty repair and return the product at the expense of the claimant.

12. Loss of warranty rights takes place in the following cases:

- a) It is not possible to identify the product from the serial number and production date on the bed.
- b) The product has been used in a manner inconsistent with the manner described in the instruction manual. The product has been used for other purposes or in conditions other than the intended ones.
- c) There has been an interference with the product, including repair of the product by an entity other than the manufacturer or authorized service of Reha-Bed.
- d) The product has been mechanically damaged (e. g. fall, hit, breaking the railings by leaning or sitting on the product, etc.).
- e) The product was damaged as a result of external factors – e. g. through contamination, flooding of actuators or the control box, use of the bed in inadequate conditions and if the product was damaged due to the user's fault (e. g. during the use of a damaged product or inappropriate equipment, overloading the bed, etc.).
- f) The product was used despite the defect.
- g) The product was damaged during transportation.
- h) The product (delivered for repair) is incomplete.
- i) Non-compliance with notes and warnings presented in the instruction manual.

Consideration of the complaint refers only to products placed on the market by the manufacturer – Reha-Bed Sp. z o.o.



REHA-BED Sp. z o.o.
ul. Spacerowa 1
41-253 Czeladź
phone (+48 32) 346 00 33
fax. (+48 32) 346 00 34
biuro@rehabed.com.pl

INSTRUC/ARIES/EN, 2026/02 REV3